

PRACTICAL GUIDE

Signal and Data lines

Surge Protection of Building Management Systems and ICT

3rd edition

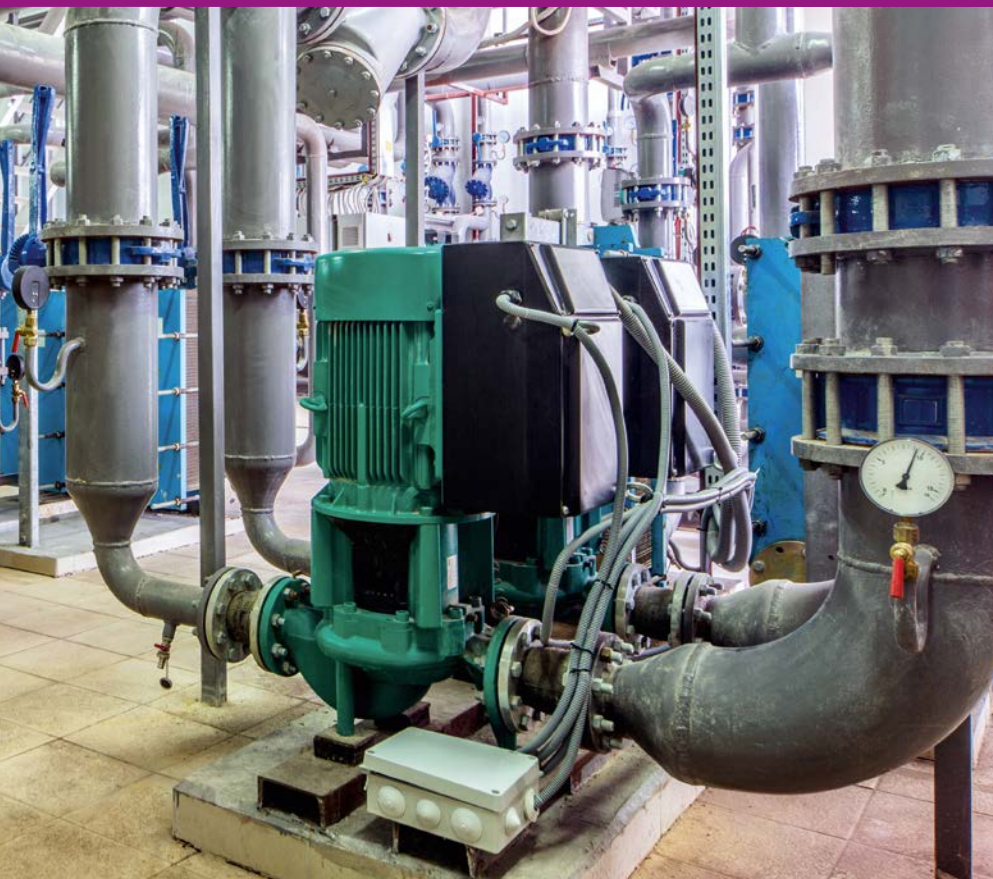

1. Overvoltage – Theory and protection

1.1. Legislation

Immunity of electronic systems to interference – EMC

In EU countries, the Electromagnetic Compatibility (EMC) Directive applies. The Directive requires that the operating equipment is not a source of electromagnetic disturbance and is immune to electromagnetic interference. EU Directive 2014/30/EU.

Standards that apply to overvoltage and interference protection can be divided into:

Standards describing requirements for surge protective devices (SPD) – testing and categorization:

- EN 61643-21 Low-voltage surge protective devices – Part 21: Surge protective devices connected to telecommunications and signalling networks - Performance requirements and testing methods.

Standards describing protected device requirements – over-voltage immunity:

- EN 61000-6-1 Electromagnetic compatibility (EMC) – Immunity standard for residential, commercial and light-industrial environments;
- EN 61000-6-2 Electromagnetic compatibility (EMC) – Immunity for industrial environments;
- Requirements on the immunity of protected equipment, given e.g. in EN 61000-4-4 and EN 61000-4-5, are divided into four test levels.

Standards specifying surge protective device applications – SPD installation, interconnection and grounding:

- IEC (CLC/TS) 61643-22 Low-voltage surge protective devices – Surge protective devices connected to telecommunications and signalling networks - Selection and application principles;
- EN 62305-4 Protection against lightning – Electrical and electronic systems within structure;
- EN 50174-2 Information technology – Cabling installation: Installation planning and practices inside buildings;
- EN 50310 Telecommunications bonding networks for buildings and other structures;
- ITU-T K.xx recommendation – Protection against interference.

1.2. What does overvoltage mean?

Overvoltage = voltage that exceeds the maximum operating voltage of the “system”. The transient (surge, impulse) overvoltage is considered being dangerous when achieving high amplitudes (kV and more) in a very short time (ns ÷ μ s), (Fig. 1).

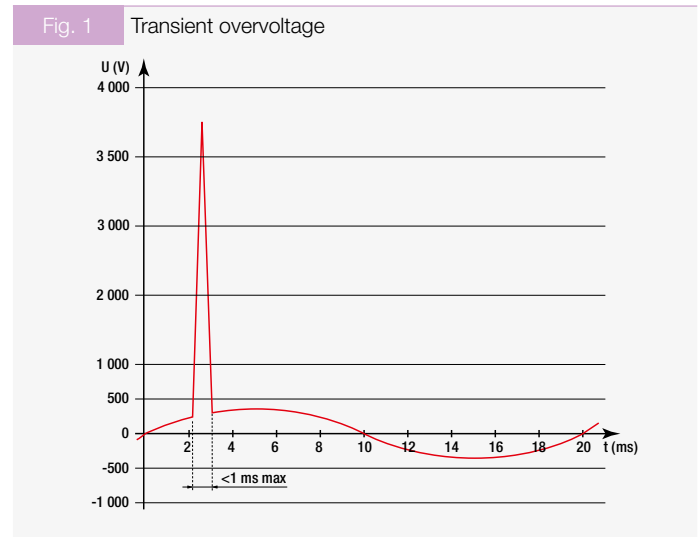

Sources of transient overvoltage

- Lightning electromagnetic pulse (LEMP) overvoltage is classified according to the cause of the damage in terms of the mutual position of the lightning strike and the building (Fig. 2).
- Switching electromagnetic pulses (SEMP) are caused by switching capacitance loads, by load variations in the distribution grid, by disconnecting inductive loads, by resonant circuits connected to switching elements (transistors, thyristors), and by network failures such as short circuits and ground connections (electric arc).
- Electrostatic Discharge (ESD)

Depending on the type of the interference source, Differential-mode and Common-mode overvoltages are distinguished.

The Differential-mode overvoltage can arise in electrical circuits when switching non-linear loads (Fig. 3a). The Common-mode overvoltage is caused by atmospheric phenomena – lightning (Fig. 3b).

Fig. 2 Lightning electromagnetic pulses

- S – a cause of the damage in terms of the mutual position of the lightning strike and the building
- S1 – strike into the building
- S2 – strike near the building
- S3 – strike into the supply line
- S4 – strike near the supply line

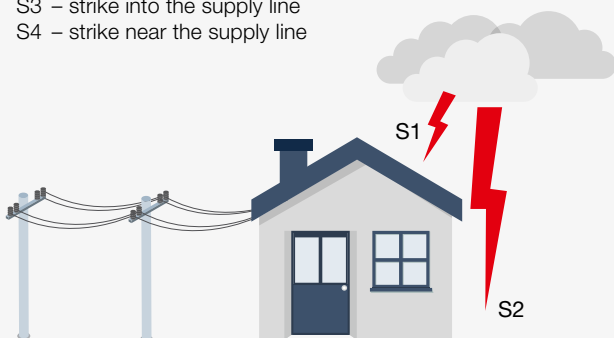

- 99% of lightning strikes are below 200 kA.
- Current pulses waveform:
 - 10/350 lightning strike simulation
 - 8/20 induction simulation

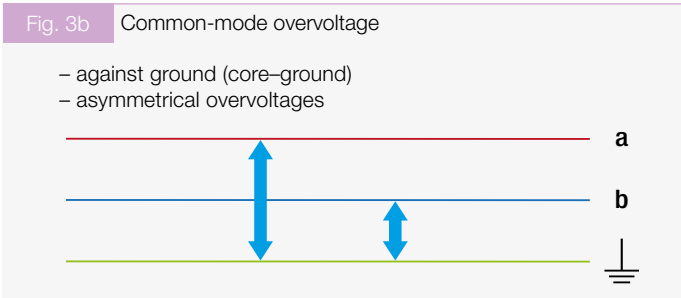
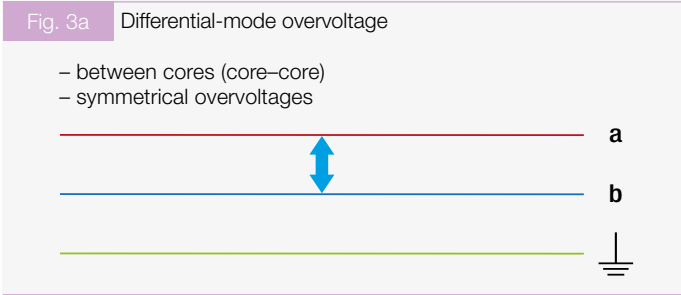

1.3. Ways of surge-pulse penetration into devices/systems and interaction of individual parts

The overvoltage is of a high-frequency nature, and can therefore penetrate to systems via low-voltage power supply, via power transformers and via circuitry of devices, via control, measuring, data and telecommunication lines and sensor loops, especially if located outside buildings or on pipelines, on rail-yards etc. and also through lightning and grounding systems.

In case of an attack of an electronic system by a surge pulse, individual parts do not behave in isolation but interact mutually – even without a galvanic connection. An overvoltage always looks for a lowest impedance ways towards grounded parts or other conductors representing the distant ground. Dashed lines in Fig. 4 represent interactions of individual parts of systems. These interactions are called internal couplings inside information technology systems. These couplings are of a very low immunity, and this immunity cannot be defined since depending on the unknown design details of the technology equipment used.

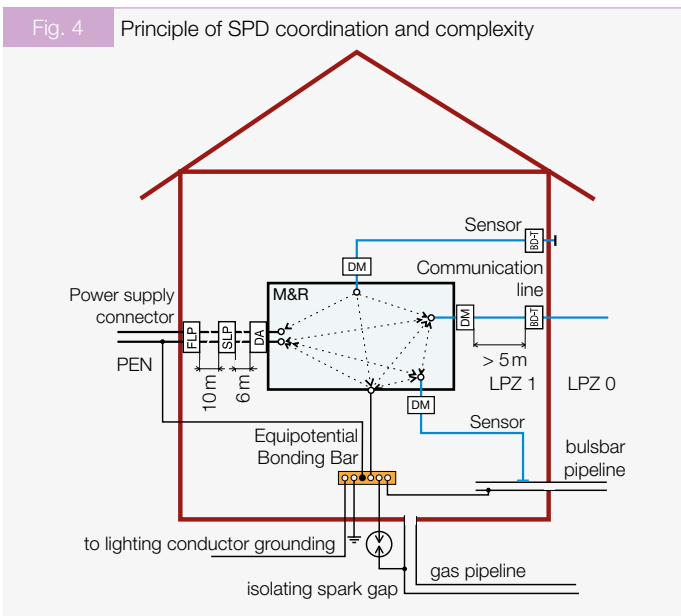

The overvoltage spreads by couplings among systems:

- via wire – i.e. by galvanic coupling (Fig. 5)
- by induction – i.e. by capacitive (Fig. 6a) or magnetic coupling (Fig. 6b)
- through the – i.e. by radiation, electromagnetic coupling (Fig. 7)

Galvanic coupling

A conductive path between the source of interference and the object of interference, either directly via line or by the puncture of insulation. This coupling is also referred to as a common impedance coupling.

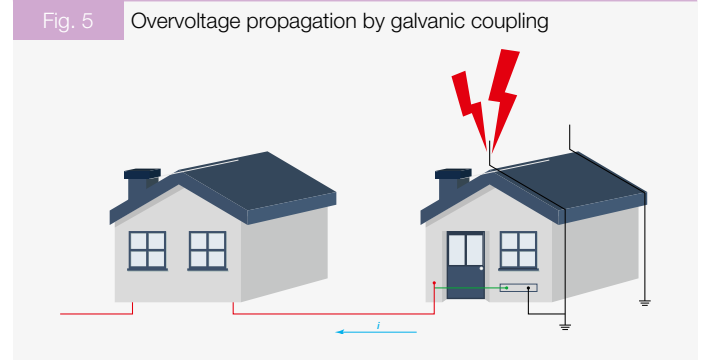

Capacitive coupling

The influence of electric field induction among circuits with a capacitive coupling. This coupling can be suppressed by a sufficient grounding.

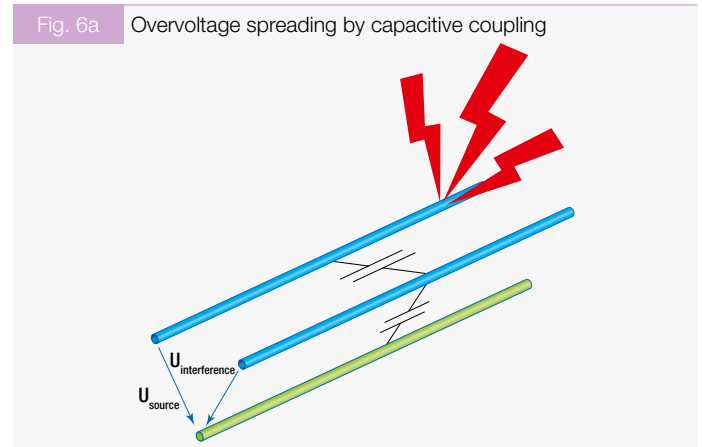

Inductive (magnetic) coupling

Circuits can influence mutually by magnetic field induction. This coupling can be described by the mutual inductance of circuits. In order to suppress this coupling a shielding is used.

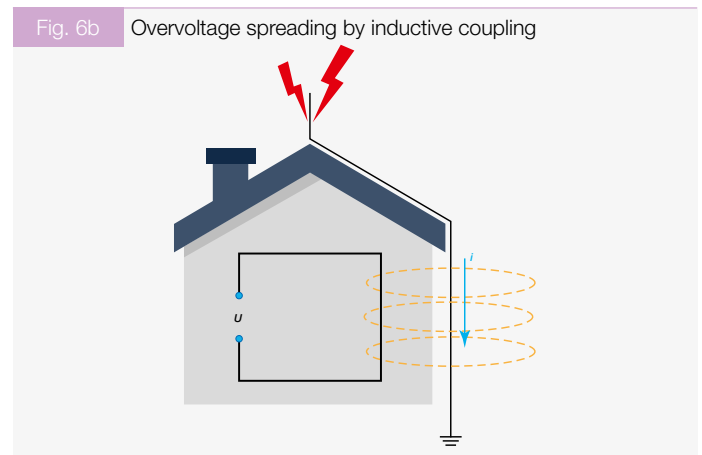

Radiation coupling

Caused by electromagnetic waves spreading from a source (atmospheric discharge, industrial disturbance – switching, near transmitters) to a disturbed object (influence apparent in case of radio receivers). An overvoltage can be induced even into off-grid systems, which are not connected to the surrounding infrastructure. So, SPDs have to be used here too.

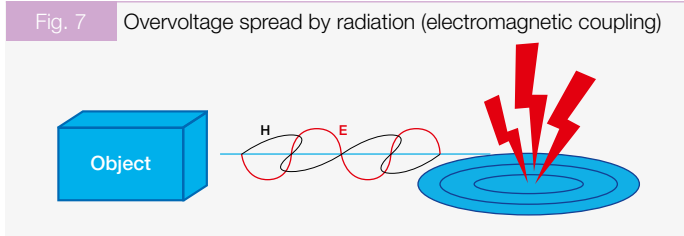

1.4. Principles of protection against pulse overvoltage

Shielding – suppression of electromagnetic field spread.

Potential equalization – suppressing current impulses on the conductive parts of an object (Fig. 8).

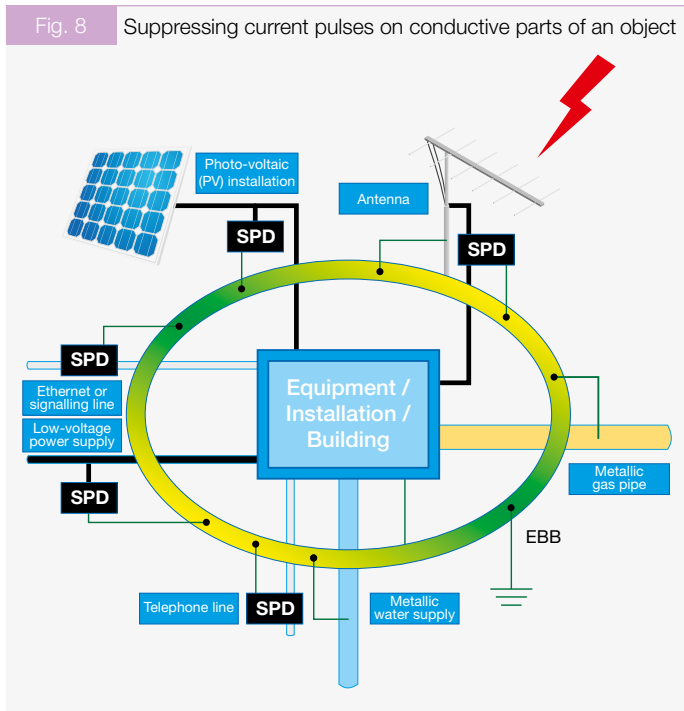

1.4.1. Main principles of pulse overvoltage protection

External lightning protection (system of lightning conductors) – protection of buildings.

Internal lightning and surge protection (SPD) – protection of technology equipments.

Potential equalization on the main bonding bar by connecting all conductive parts:

- direct connections are established wherever possible – lightning conductor system, protective earth (PE), water supply, metal jacket of cables (shielding), heating pipes, etc.
- indirect connections by lightning arresters (SPD T1, SPD ST1) and surge protective devices of all “live” wires of power and communication lines (SPD T2, SPD ST2 + 3).

1.5. Classification of SPDs according to lightning protection zones (LPZ)

SPDs are installed at an boundary of individual LPZs where they are also connected to an appropriate potential equalization (Fig. 9 and Fig. 10).

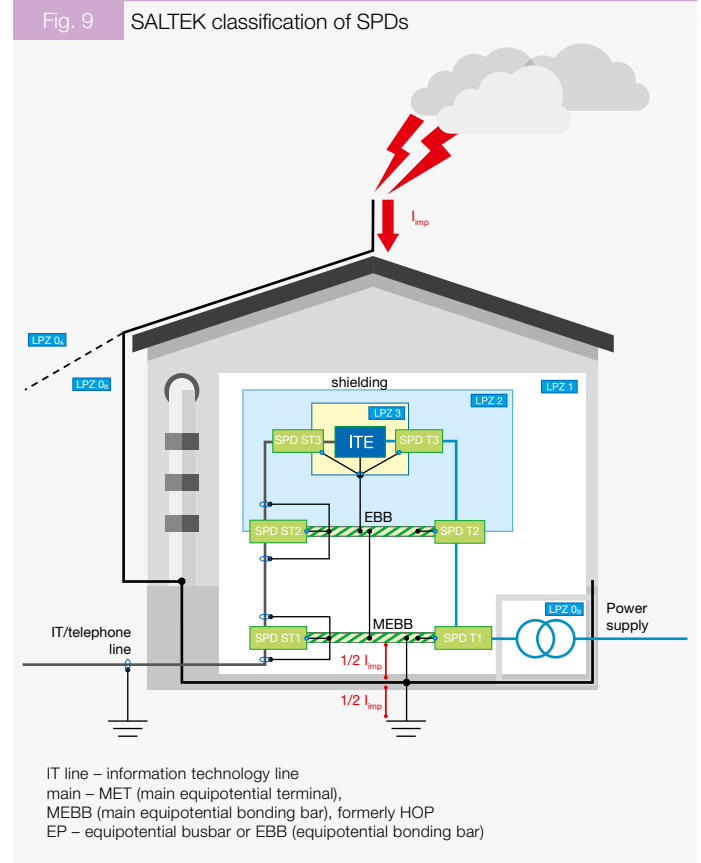
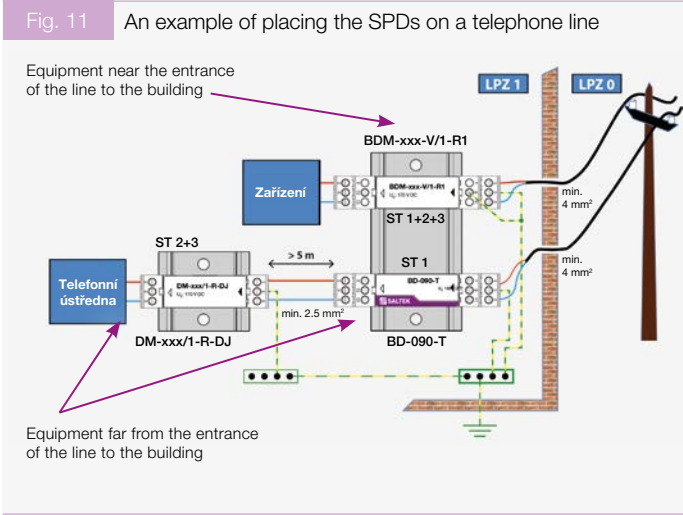

Fig. 10 SALTEK classification of SPDs

SPD location (SALTEK)	Classification EN 61643-21	Installation			Test
		Boundary of zones	Location	For risks	
ST 1	D1	LPZ 0/1	To the building entrance	S1 or S3 with galvanic coupling	$i (10/350)$
ST 2	C2	LPZ 1/2		S1 or S2 and inductive coupling	$u (1,2/50)$ $i (8/20)$
ST 3	C3 (C1)	LPZ 2/3	Close to ITE		$u (1 \text{ kV}/\mu\text{s})$
ST 2+3	C2, C3	LPZ 1/(2)3	Close to ITE	The combination of row 1 and 2	The combination of row 2 and 3
ST 1+2+3	D1, C2, C3	LPZ 0/(1, 2)3	To the building entrance and close to ITE	The combination of row 1, 2 and 3	The combination of row 1, 2 and 3

ITE = Information Technology Equipment

The SPDs ST 2+3 or ST 1+2+3 are located directly at protected technology equipments because nothing like a sub-domain distribution board exists for data lines (where the SPDs type ST 2 would be placed). The SDP ST1 is placed at the communication line entrance to the building if the technology equipment is located far away from the entrance. If the technology equipment is close to the communication line entrance to the building the SPD ST 1+2+3 is used (Fig. 11).



1.6. The SPD installation principles

1.6.1. Principles of installing cables to cable trays:

- The minimum separation distance between information technology cables and power supply cables has to include any additional deviations for the movement of the cables between their fixing points or other limitations (e.g. cable deflection).
- The requirement for minimum separation is applied in three dimensions. If the information technology cables and the power supply cables are required to cross the angle of their crossing must be 90° on each side up to a distance longer than the required minimum separation distance.
- In accordance with requirements of the corresponding article of the standard, power supply cables and information technology cables must not be in the same bundle and different bundles have to be isolated and shielded.

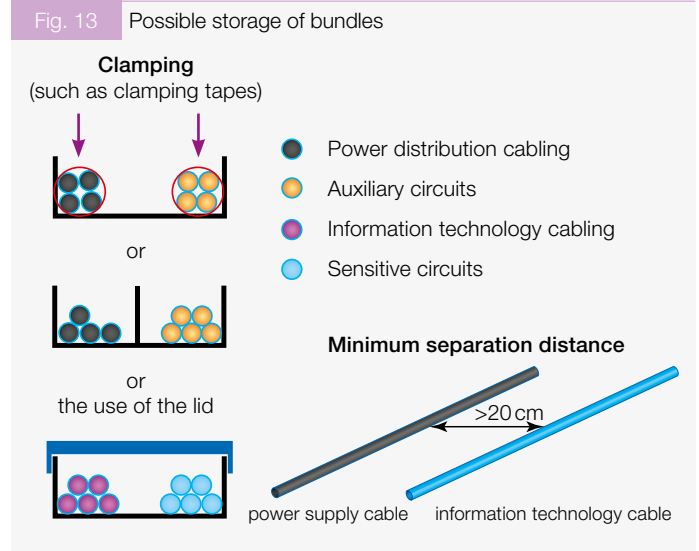
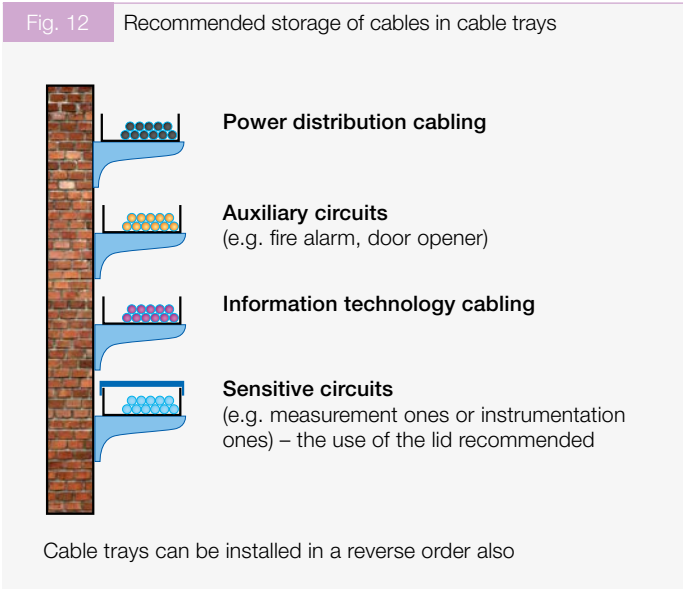

1.6.2. Wiring principles of SPD

Data lines operate with low voltage levels e.g. the RS-485 communication operates with a voltage of 5 V. Therefore, even a very small induced disturbance (e.g. 20 V) may have a damaging effect on the Information technology equipment. This is the reason why special care of possible couplings between input and output lines has to be taken in system of information technology, especially (Fig. 14a and 14b).

If the switchboard of technology equipment consists of more communication lines then multi-row solutions have to be adopted with respect to coupling between input and output lines (Fig. 15a and 15b).

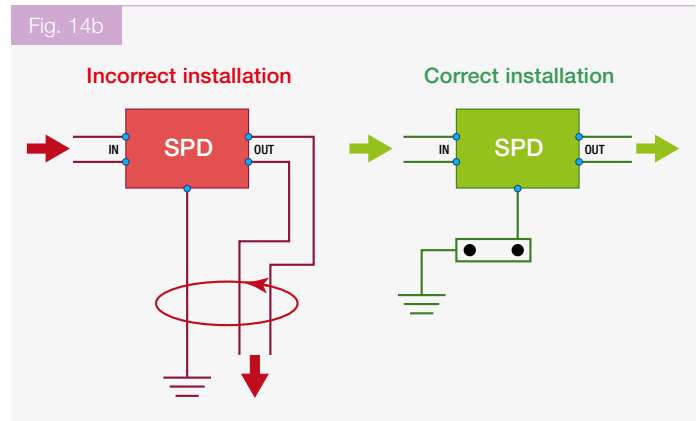
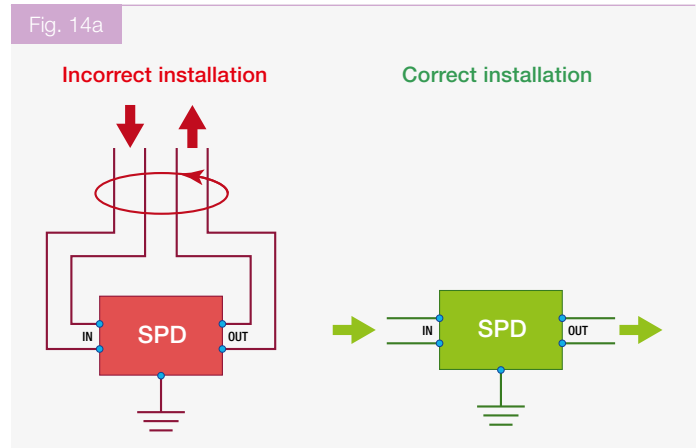
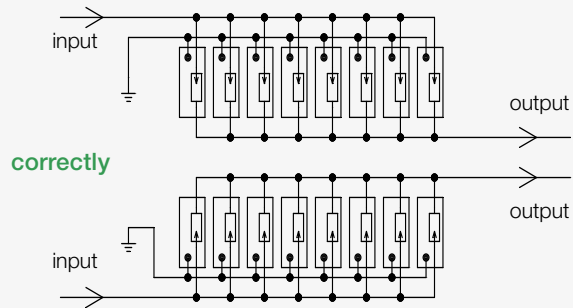

Fig. 15a Coupling between input and output lines and grounding

Principle

Separated input and output



Implementation

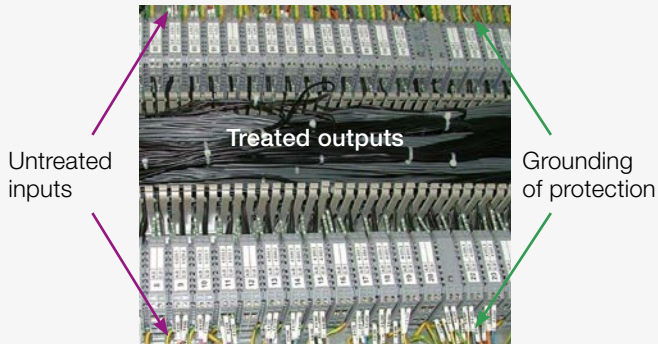
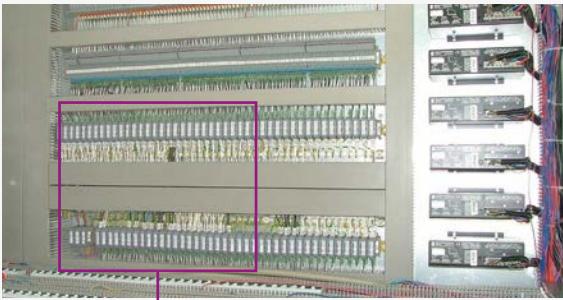
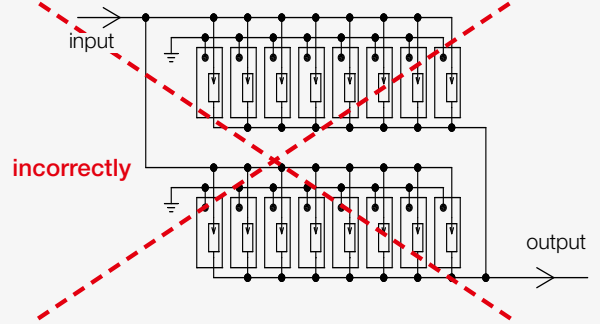

Fig. 15b Coupling between input and output lines and grounding

Principle

Coupled input – output



Implementation

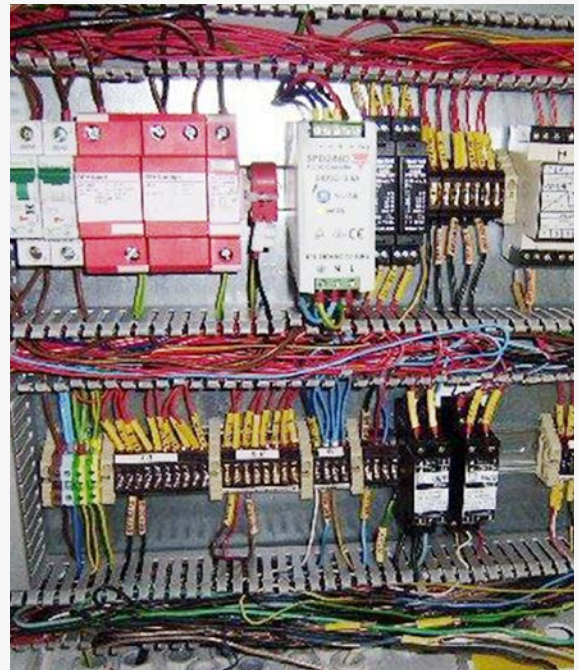

Fig. 16 Incorrect protective ground connection

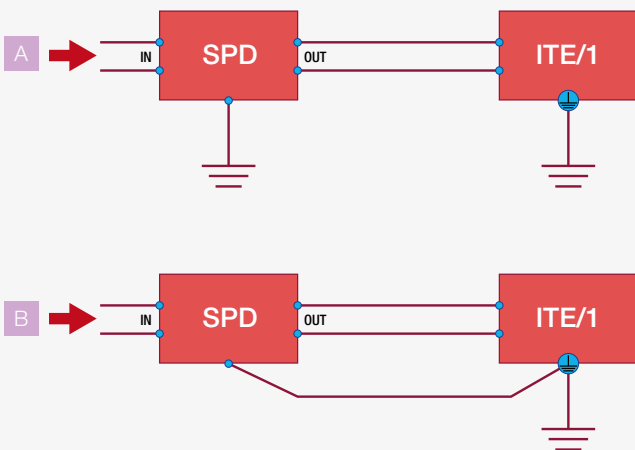
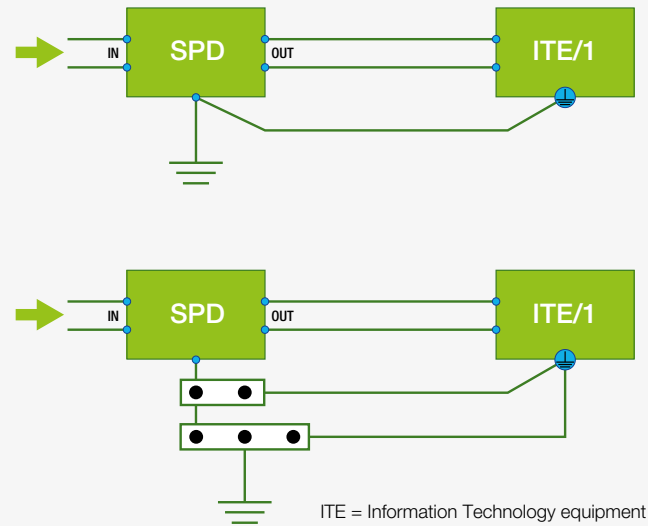

Fig. 17 Correct connection



ITE = Information Technology equipment

Connecting of protective ground to a surge protective device (SPD) is very important. In this case, it is necessary to take into account the internal couplings in the technology equipment (Fig. 4). The SPD has to be therefore connected to the same protection potential as the technology equipment. Typical faults of connecting protective grounds are in Fig. 16.

Fig. 16 part a shows the effect of internal coupling of the technology equipment when the protective grounds are connected improperly. Fig. 16 part b shows the superposition of the fault voltage on the technology equipment with an unwanted induction into the communication line and a potential damage of the given input.

The correct connection of the protective ground of the SPD and the technology is shown in Fig. 17 where both grounds are connected to the same potential, and the fault current cannot be induced into the protected communication.

1.6.3. Principles of grounding and interconnection

In multistorey buildings the interconnection network has recommended to be installed on each floor (Fig. 18). Each floor has a specific type of a network. These interconnection systems on separate floors should be connected by wires in two points at least. The interconnection system on each floor should be connected to the common protective ground of the technology equipment and related SPDs in a way corresponding to the character of the technology equipment.

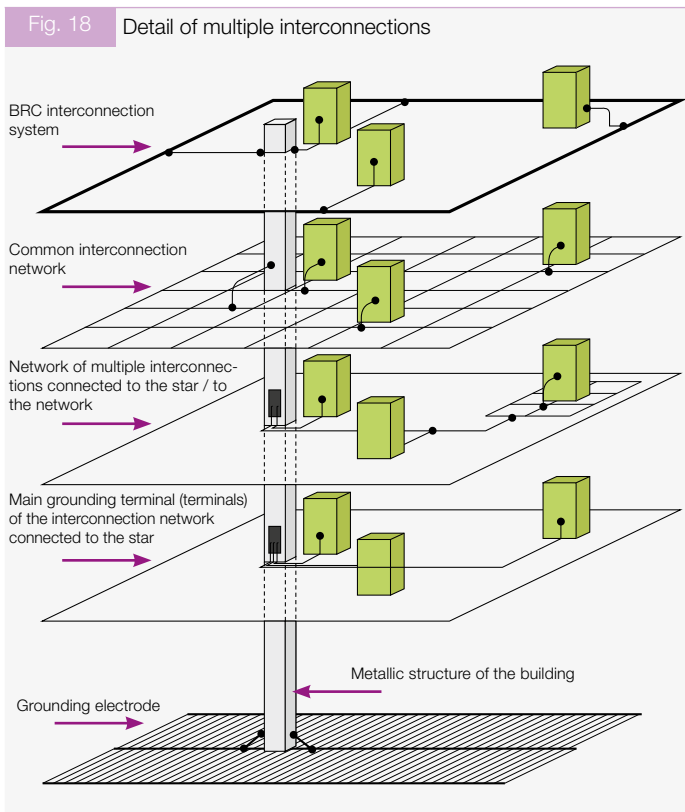

1.6.4. Shielding installation rules for overvoltage and disturbance protection

If the shielded cable passes rooms complying with EN 50310 for spaces with information technology equipments, and interconnection is installed as a grid the shielding has to be connected to the grid according to Fig. 19. If these principles are not met and the shielding can not be connected to ET at the second end of the cable directly (because of different voltage potential of distant bonding bars), the shielding has to be connected via SPD according to Fig. 20 there.

Fig. 21 shows the way of linking two objects by a metal pipe so that the communication line does not need to pass through LPZ 0/1 boundaries. This approach is called zone shaping and substitutes ST1 protections that are necessary otherwise. Next we show the correct connection of a shielding of a shielded cable between two objects when passing LPZ 0/1 and providing protection against atmospheric overvoltage at the same time.

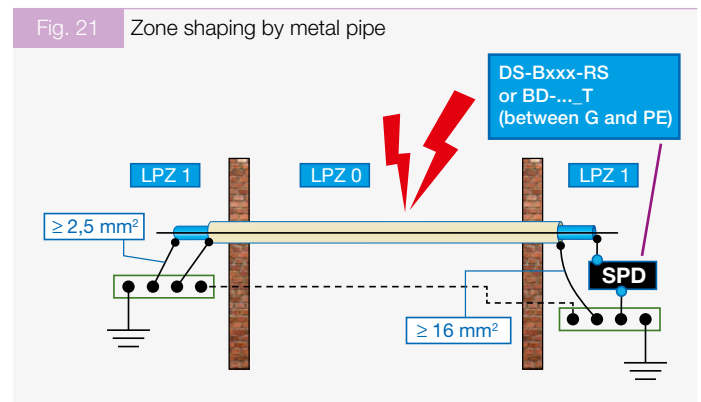
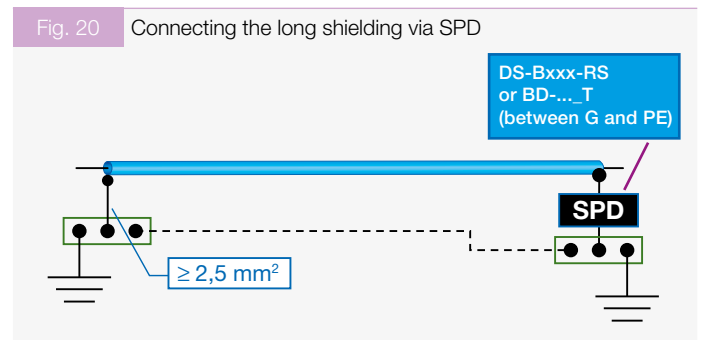
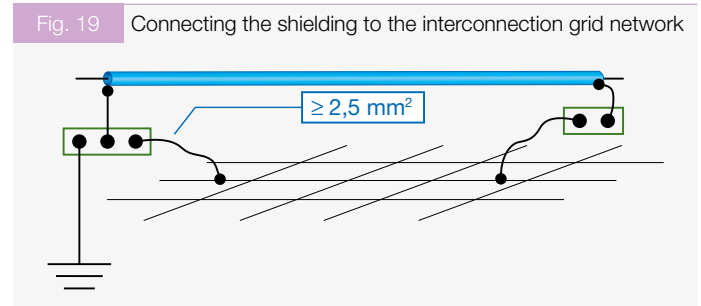

1.7. Components for protection of data lines against overvoltage and their coordination

Components with different reaction times and different protective capabilities are used for the protection of information technology systems. Consequently the SPD can either lead a huge amount of energy (but is slow) or a small amount of energy (and is very fast). E.g. gas lightning arresters or suppressors. If the surge protective device should be both efficient and fast, both types of components have to be combined. In order to ensure a proper common function of such heterogeneous components, their coordination has to be performed.

The requirement to reduce overvoltage in data lines is very strict. The residual overvoltage has to be reduced to a nominal voltage level or as close as possible. Immunity and response of protective devices have to be high. A sufficient surge protection cannot be achieved when using separate components those have been mentioned.

Usually, several protection components have to be arranged properly to achieve the desired function of surge protective device. Components those can handle large currents in a slow reaction are combined with very fast components those are unable to lead such an amount of energy. That way, overvoltage pulses are limited to a value that is not dangerous for the function of the protected equipment. As a coarse (primary) protection a gas lightning arrester is usually used. A fine (secondary) protection consists of a suppressor diode, a varistor or a Zener diode. Fig. 22 shows the principle of coordination of these components.

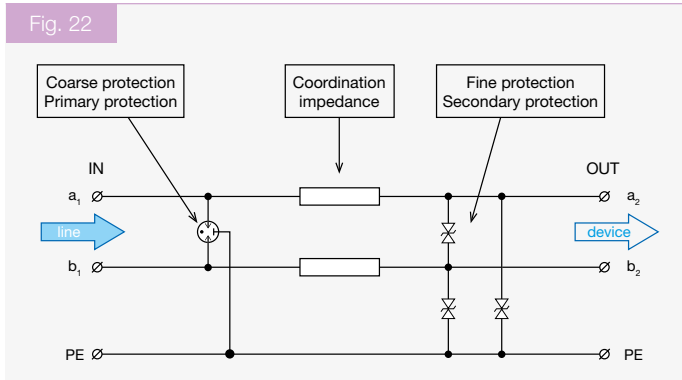

1.8. Design and installation of pulse overvoltage protection

1.8.1. Principles of protection design

When designing the overvoltage protection for Information technology systems, specific system layout has to be taken into account.

Power supply lines, data network inputs, communication line inputs, inputs for connection of measuring sensors or converters and lines to actuators are the “gates” for over voltage or disturbance introduction into Information technology systems. The threat is significantly higher if connecting lines are installed outside buildings with a risk of a lightning strike.

Another hazards are caused by sources of strong electromagnetic fields which always contain undesired high-frequency components. In these situations appropriate high-frequency filters or a combination of a filter and a surge protective device have to be installed to power supply lines close to protected equipment. Suppression of high-frequency disturbances in signal, measurement or communication lines is very difficult. Those phenomena usually indicate an incorrect design or an improper installation. Galvanic isolation of signal is considered to be a sufficient protection of lines. Let us emphasize that the galvanic isolation of the data line is primarily intended to isolate the line input from the common-mode voltage. However, used integrated circuits do not have a sufficient insulation resistance which can be even reduced by an improper design of the printed circuit board, by the residue of the soldering flux, by the parasitic capacitances among separate circuits, etc. In case of a high-energy pulse an arc can appear at the outlets and pulses can be superposed to other circuits.

1.8.2. Main rules of overvoltage protection design

- high-quality project preparation
- properly dimensioned interconnection with the equipotential bonding bar (attention has to be paid to possible inductive loops)
- line protection at the entry into the building by coarse protections – lightning arresters (immunity up to 5 kA in wave 10/350 μ s)

- protection of measurement and regulation devices by installing the SPDs type 3 or ST3
- elimination of parallel guidance of data lines with power lines
- selection of a proper type of a lightning arrester and a surge protective device has to respect the nominal voltage, current and maximum signal frequency

Complexity and coordination of the SPDs is the fundamental principle for overvoltage protection. The complexity means that all inputs of the device (power, data and telecommunication interfaces) are protected. The coordination means that protectors with different protective effects are ranked along the line to protected equipment safely and systematically.

SALTEK data SPD ranges DM, DL and VL are two-stage protections with a nominal discharge current of 10 kA (8/20 μ s). This value is sufficient for most applications. If the line is installed in outdoor environment (air, facade, etc.), or the line is a ground cable, the surge protective devices have to be completed by the ST1 protection – the lightning arrester – of the range BD-xx or FX-xx, rated for lightning current up to 2.5 kA (10/350 μ s) or 10 kA (8/20 μ s). These lightning current arresters are recommended to be installed just behind the entry of the outdoor line (cable) into the building.

Ranking BD or FX range protections and DM, DL or VL range protections an alternative to the 3-stage protection for data lines can be created.

- the 1st stage – SALTEK lightning arrester, range BD or FX for coaxial lines,
- the 2nd and the 3rd stage integrated into a one SALTEK arrester range DM-xx, VL-xx and DL-xx.

The minimum distance between the coarse protection (range BD-xx) and the combined medium and fine protection e.g. range DM, etc. should be 5 m. If this can not be ensured, the coordination of the protection has to be ensured in a different way for example by SPD ST 1+2+3.

The correct functioning of surge protective devices depends on a correct grounding. The PE terminal of SPD has to be connected to a suitable grounding point by a yellow-green wire with a cross-section of min. 2.5 mm² for ST 2+3 and a cross-section of min. 4 mm² for ST 1. The protective ground of the protected equipment in compliance with valid EN standards has to be used also for grounding of protective devices (SPDs).

If the protected equipment is not connected to the power supply network, another grounding has to be used in compliance with valid EN standards. The grounding has to be connected to the frame (shielding, etc.) of the protected equipment. The resistance of this grounding should not exceed 5 Ω but declared parameters of protective devices are met at values not exceeding 2 Ω .

Input and output terminals of SPDs can be used to connect wires of the cross-section 0.35 to 2.5 mm². Correct and incorrect grounding of the SPD and the protected equipment is in Fig. 16 and 17.

When installing, untreated input lines have to be ensured to be as far as possible from the treated (clean) output line. The way of grounding of shielding in shielded cable networks is not affected by the installation of protective devices. However, the unshielded end of the shielding has to be protected against the effects of pulsed overvoltage by a lightning arrester, e.g. DS-B090-RS (RB), see Fig. 20 and 21.

This protection is already done at SPDs with connection via connectors (range VL, DL, etc.) – the shielding is protected by a full surge protection against the protective ground.

SPDs have to be in principle placed such a way so that the output line to the protected equipment can be as short as possible. **Observe principally direction of SPD connecting: input – towards the line, output – towards the protected device. The direction of connecting is displayed on the body of the SPD by the full/empty arrow and the IN/OUT text.** If correct orientation of the surge protective device is not kept the protection does not meet declared parameters and can be destroyed.

The Fig. 23 shows the connection of protective devices (SPDs) on the communication line.

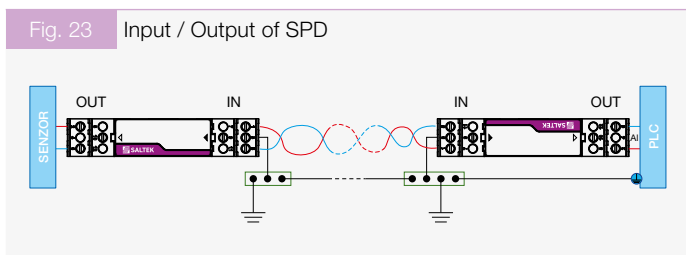

1.9. Selection of SPDs according to parameters of protected interface

Nominal voltage U_c . The amplitude of the transmitted signal (incl. approx. 10% tolerance) must not exceed the nominal voltage U_c of the protective device, otherwise the useful signal may be reduced (clipped) or the power supply may be damaged. The lowest nominal voltage should be therefore chosen which still does not reduce the useful signal. The minimum residual overvoltage at the input of the protected device can be ensured that way.

Nominal load current I_L . In the loop it must not permanently exceed the value given in the table of technical parameters.

Impulse current I_{imp} . At SPD type 1 or ST 1.

Maximum frequency f . If the frequency of the transmitted signal exceeds the maximum frequency of the used protective device, an excessive attenuation of the transmitted signal (> 2 dB) can occur.

Location in LPS. Definition of right LPZ.

Type of the line. The number of cores and if the common wire is connected or isolated to the ground.

1.10. SPD installation – safety rules

Installation of surge protective devices may be carried out by qualified personnel only. The valid technical standards must be complied during installation of SPDs.

The use of protective devices is permitted only within the scope of conditions given in the installation manual. If the use of the protective device does not respect specified conditions e.g. exceeded nominal voltage, current, etc., or the SPD is loaded above the specified conditions e.g. the direct lightning stroke to the line the SPD and the connected equipment can be destroyed. Never install a mechanically damaged SPD. The damaged SPD should be sent to the manufacturer for inspection and repair. Never open the SPD. Any intervention may result in the destruction of the SPD. Any SPD intervention causes the loss of warranty.

1.11. Maintenance of the SPDs

Supplied devices are maintenance-free. During regular inspections equipment is checked from viewpoint of integrity and conductivity of grounding wires, and the type of operation, used conductors and tightening screws in terminal blocks. Damage of SPD during overload usually appears to be a short circuit or an interruption of line. Damaged protection is never repaired but replaced with a new one.

1.12. Ranges of SALTEK SPDs for data lines

- pluggable modules design
- compact design
- terminal block design
- LSA bars
- in a metal case with connectors (DL, VL, FX)
- in special metal case (HX, ZX, SX)
- special design

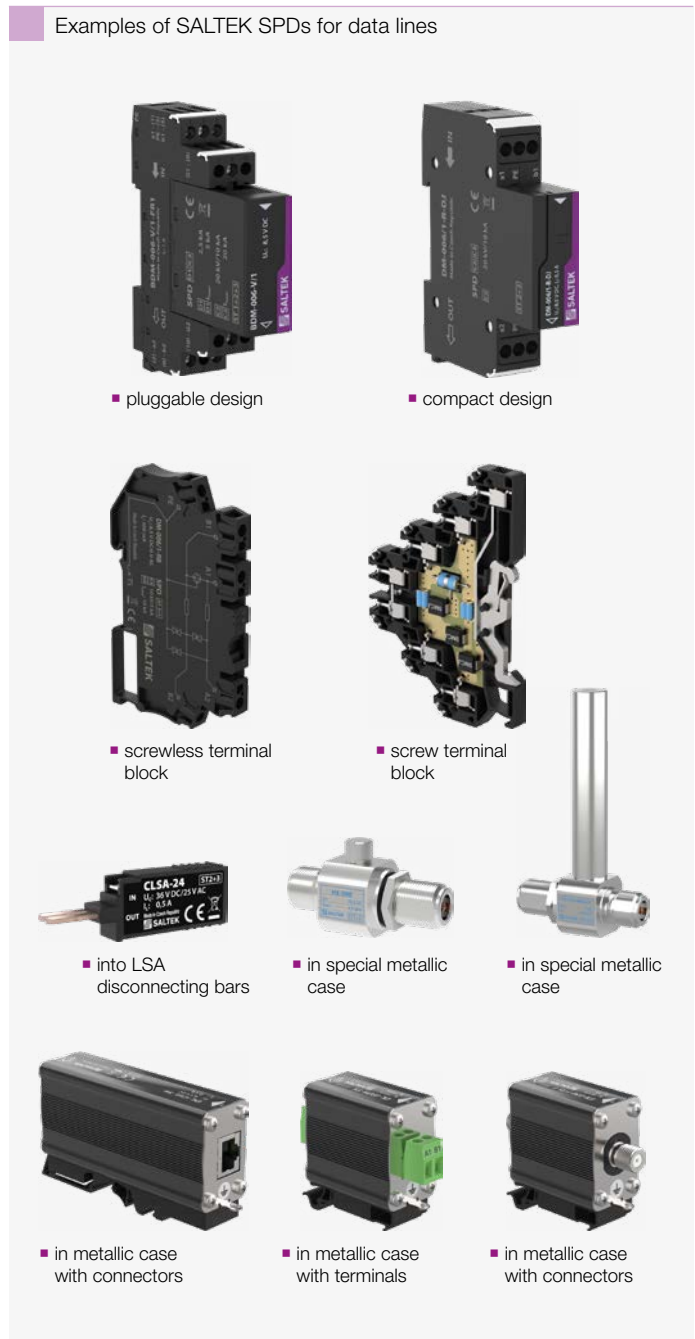

1.12.1. Marking INPUT – OUTPUT of SALTEK SPDs for data lines

Fig. 24a SPD input

- always in the direction towards the incoming line (cable)
- marking IN = INPUT
- terminals x1 (a1, b1,...)

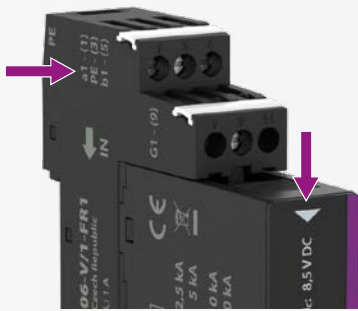
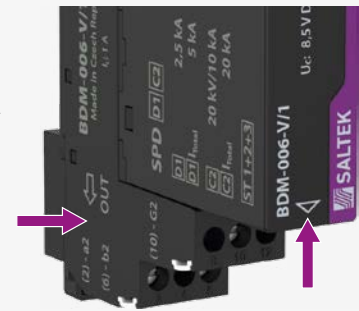

Fig. 24b SPD output

- always in the direction towards the protected device
- marking OUT = OUTPUT
- terminals y2 (a2, b2,...)



1.12.2. Code matrix of SALTEK SPDs for data lines

Compact design – ST 2+3

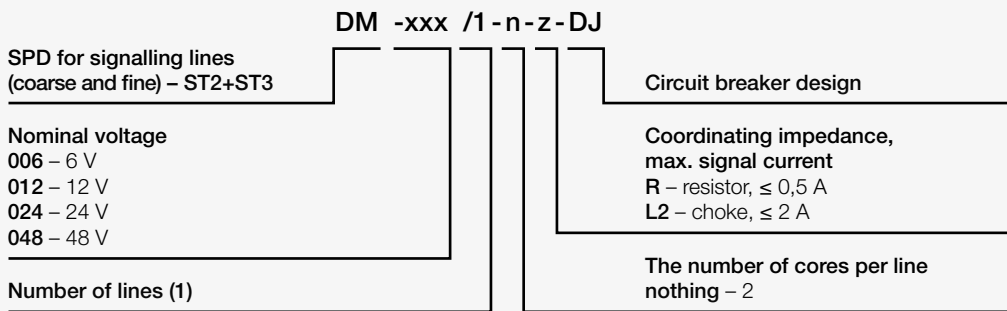

Compact design – ST 2+3

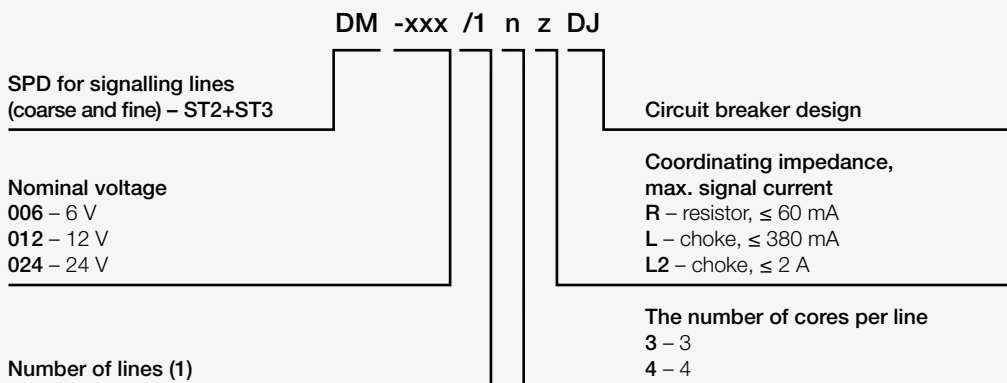

Design with pluggable modules – ST 1

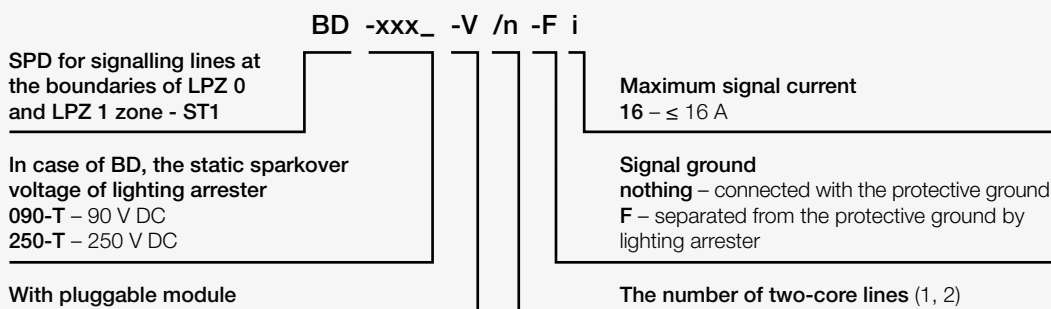

Design with pluggable modules – ST1+ST2+ST3

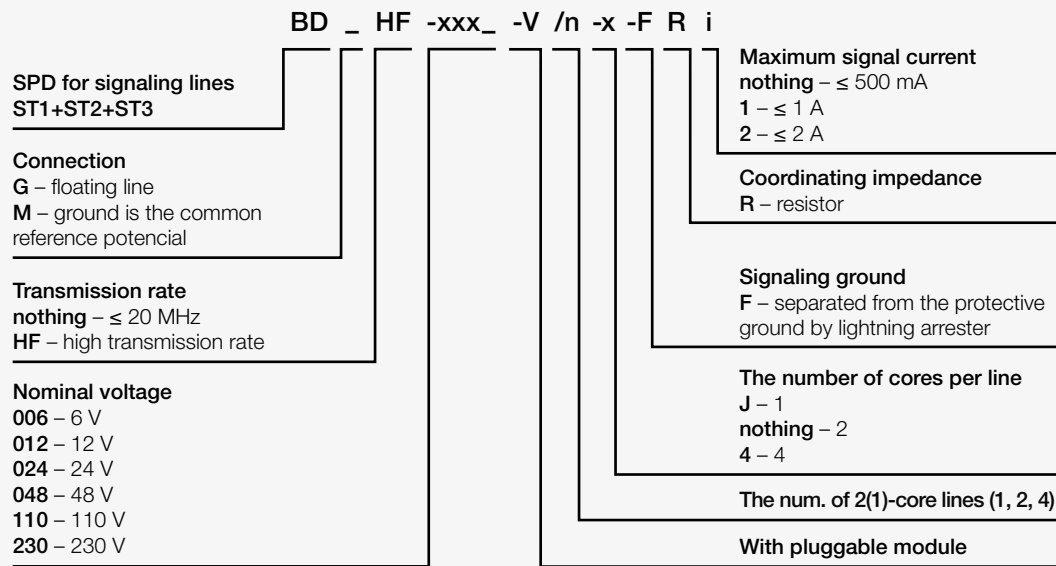

Design with pluggable modules – ST 2+3 (power supply and signalling line combination)

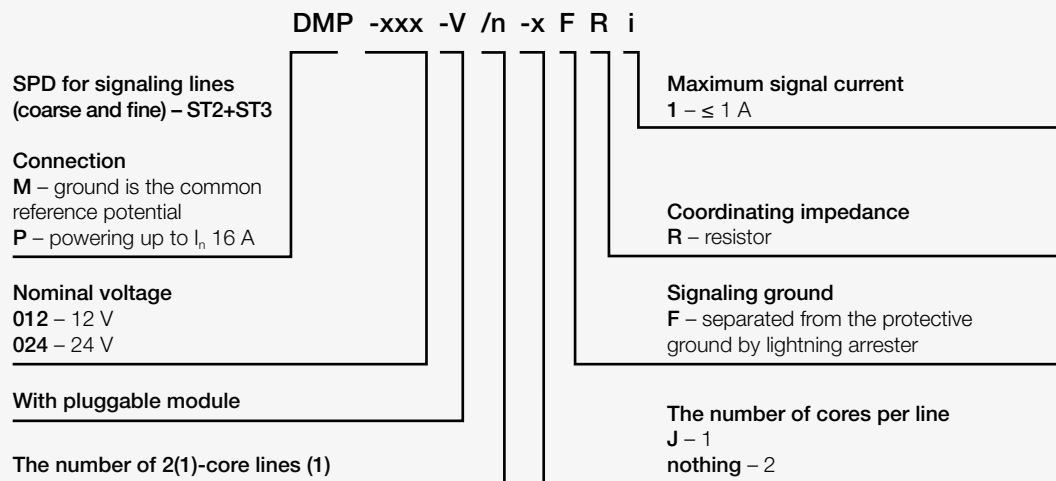

Terminal block design – ST 2+3

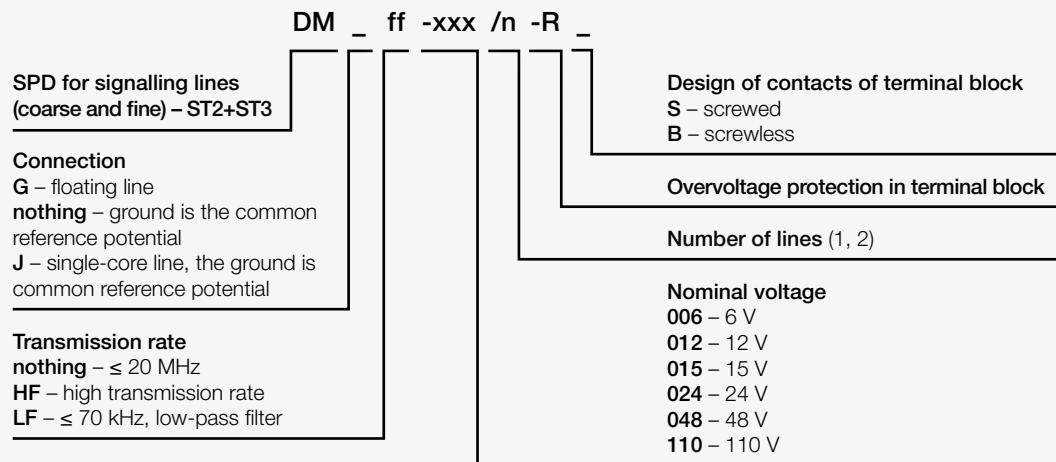

2. Examples of SPD Application – Power supply protection

2.1. Low Voltage power supply protection

For Information technology devices/equipments/systems which are supplied from the distribution network 230/400 V AC, a sufficiently low level of over-voltage has to be ensured that corresponds to the nominal pulse voltage U_w of the Class I devices, i.e. below the level of 1.5 kV reduced for 20%, i.e. to 1.2 kV. To have the protection sufficiently effective, a three-stage cascade of particular types of SPDs has to be installed in appropriate switchboards. The last stage of power line protection (SPD T3) must not be in a longer distance than 5m from power supply terminals of protected device (Fig. 25).

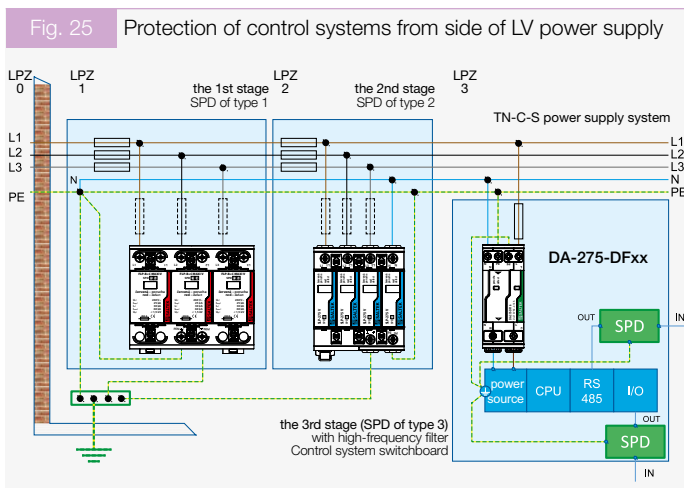

For Information Technology without processor, SPD type 3 without RF filter is suitable, such as the DA-275-DJ25 type. (could also be equipped with remote signalling contact)

If a Information Technology system is controlled by a processor (electronic security systems, electronic fire alarms, PLCs, access control systems, etc.), the SPD protection type 3 has to be equipped with a high-frequency filter aimed to eliminate the effects of undesired transient pulses in the power supply network those can be caused, e.g. by a drilling machine. The SPD does not respond to these pulses due to their small amplitude (hundred volts). So, the pulses penetrate to the system, which is not destroyed, but the processor can freeze or can be damaged, and memory chips can be erased, resulting in malfunction of the system. In this situation, the SPD type 3 is therefore appropriate being used with a low-pass filter, e.g. DA-275-DF16 which is capable to solve the problem. The principle of connection and filter function are in Fig. 26.

Fig. 26 An example of wiring the SPD of DF range in the TN-S (TT) network with the power supply response before and after protector.

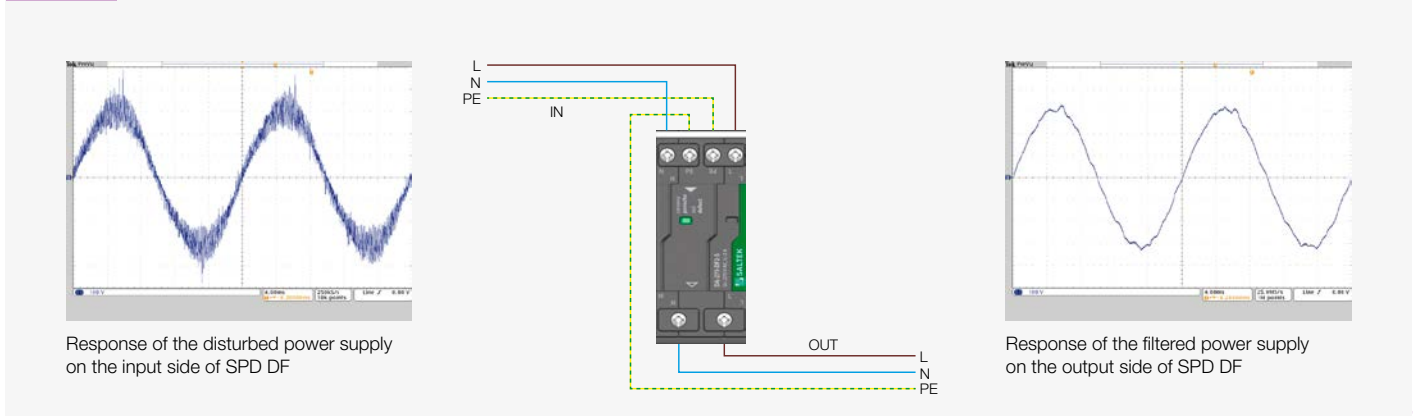

If a Information Technology system is equipped with an additional power source e.g. switchboard of electronic security systems or electronic fire alarms, the SPDs type 3 with a high-frequency filter with a power interruption (e.g. type DA-275-DF16) are recommended being used. If the SPD is damaged, the power supply is automatically disconnected and the system is switched to a backup power source and reports a power failure. This prevents the system from being unprotected and the next pulse penetrating via the power supply will not destroy the system.

2.2. Small Voltage power supply protection

For Information Technology systems those are powered by various DC or AC small-voltage sources, a sufficiently low level of surge over-voltage has to be ensured that corresponds to the ICT equipment operating voltage.

For this purpose, SALTEK offers SPD range DP (ST 2) for small voltages from 12 V to 60 V (Fig. 27). If the processor of system equipment powered by small voltage needs to be prevented from freezing and the effect of RF disturbance needs to be eliminated then the power protection combined with the low pass filter is appropriate again, e.g. type DPF.

Obviously, the three-stage SPD cascade on the low voltage side is again assumed to be installed in front of the small-voltage power source.

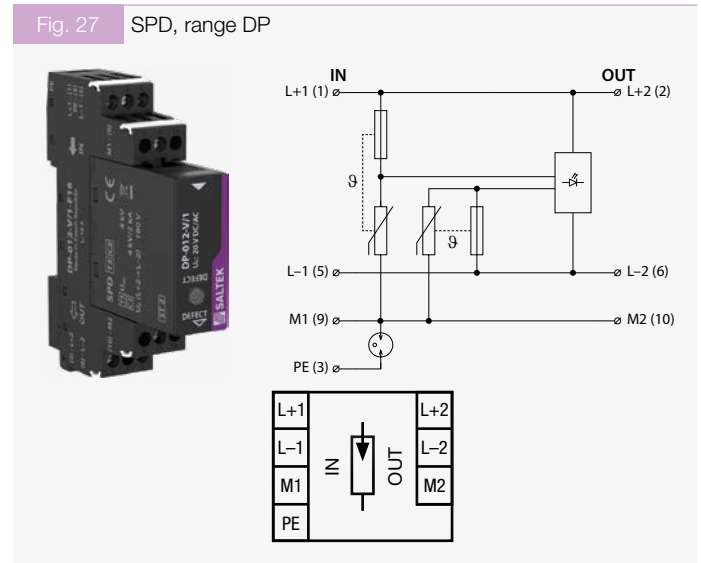

3. Examples of SPD Applications – Measurement & Regulation

3.1. Protection of distributed M&R control systems

The effect of pulsed overvoltage or RF disturbance can cause the collapse of the information and control systems of the technology equipment. Damages and losses resulting from overvoltage or RF disturbance are becoming higher and higher. This is due to the continued miniaturization of these systems, and consequently, their lower immunity. Subsequent losses due to production outages, loss of data and information are often even higher than direct damage to the equipment. In addition, a serious manufacturing breakdown might occur in industry. Distributed systems are particularly prone to overvoltage failure. Separate parts of the system might have different potentials and might be powered from different power supply lines. These systems usually include long lines. An extensive M&R system in a power plant or data network (Ethernet) are typical examples of distributed systems. An example of such a system is shown in Fig. 28.

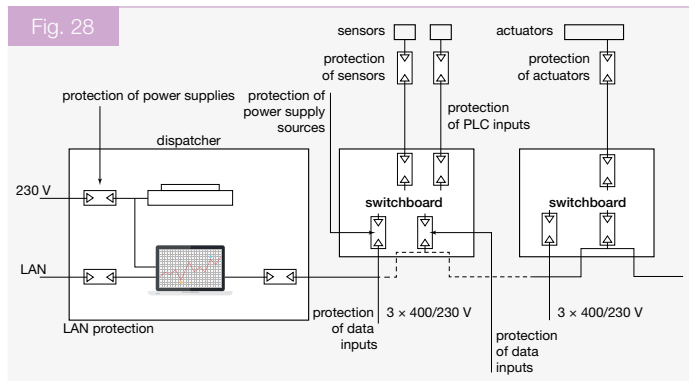

In the control computing system, power supply sources of all devices have to be protected against overvoltage peaks from the power supply network. If the system is connected to a LAN, the LAN input is recommended to be protected as well. In the switchboard of a distributed system, the single phase line of power supply sources of electronics is recommended to be protected at least. Superior levels of SPD are usually installed in the parent switchboard or the main switchboard. The inputs of the data bus are protected at the input of the switchboard. If remote sensors (current loop transducers, switches, etc.) are connected to the devices, measuring inputs connected to these sensors are necessary to be protected as well. Outputs to actuators e.g. proportional valves, inverters have to be protected the same way. If sensors or actuators include electronic circuits amplifiers and transducers for standardized signal, inputs and outputs of sensors are recommended to be protected too. This principle is shown in Fig. 29.

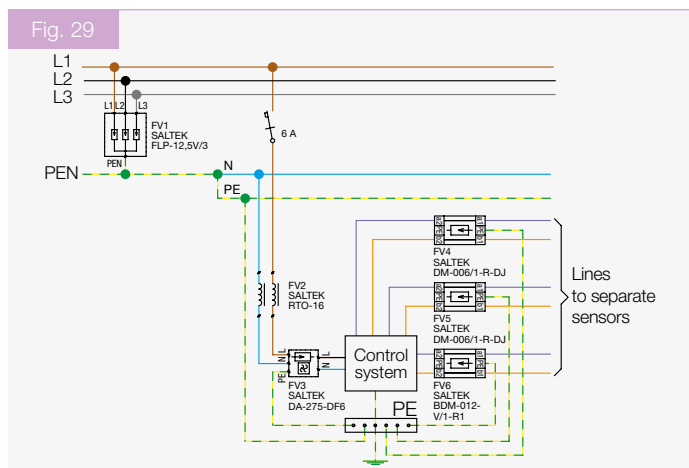

If remote power supply of sensors is used (either DC or AC), the power supply sources and sensor stabilizers are recommended to be protected also.

The data line protection should be included into the switchboard input. At a higher transmission rate, the cable is necessary to be properly connected, which should not form stubs and should maintain linearity. For RS-232, BDG-012-V/1-4FR1 is recommended. For RS-422 (two pairs), the protection BDG-012-V/1-4FR1 or BDM-012-V/2-FR1, and for RS-485 is BDM-006-V/1-FR1 recommended. In case of shortage of space, DM-006/1-RS or DM-006/1-RB are recommended. These SPDs are narrow terminal blocks (6 mm wide) with a screw terminals (RS) or a screwless terminals (RB), (Fig. 30a and 30b).



3.2. Protection of sensors and sensor inputs

The protection of inputs and outputs of control units is as important as data line protection. Voltage peaks causing malfunctions or destruction of the device might appear on input lines of sensors as well. In many cases, also sensors and actuators should be protected, when containing electronic circuits especially. Again, the protection should be installed near the equipment to be protected. The protection must not affect the function of the sensor and should not affect the accuracy of output data of the sensor. If this effect cannot be eliminated, the impact of protection on the total deviation of sensor data has to be known and has to be considered.

Protection of digital inputs

Sensors connected to digital inputs with a long line are related to a different potential and powered from another source. Then, the digital inputs should be protected even if insulated in a galvanic way. In real life, protection of the input for a potential-free contact and for the sensor with open collector output can be considered.

Fig. 31 shows an example of input protection for binary signals by a compact and pluggable version of SPD.

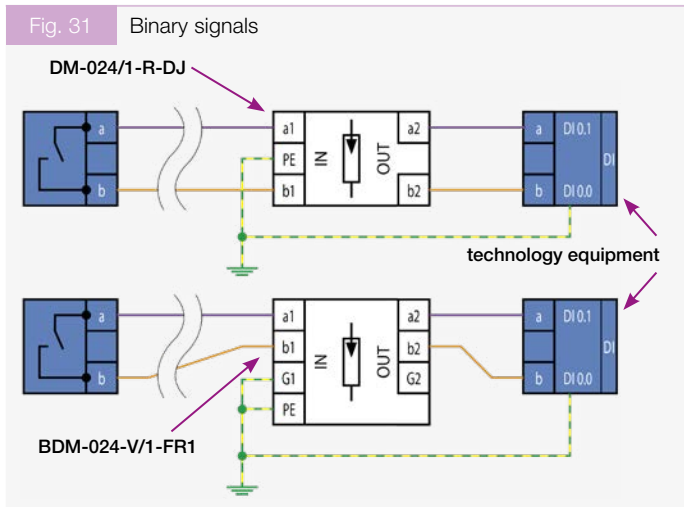

For multiple binary signals with a single common non-grounded wire, the principle of protection is shown in Fig. 32: the protection of binary inputs and outputs of power elements with ungrounded common pole is shown here, including protection of the power supply source.

Fig. 33 shows the principle of wiring in case the common wire is grounded. The figure specifically shows wiring with the grounded positive pole of the DC power source. If the negative pole of the DC power source is grounded, then the plus and the minus have to be swapped in the schematics, and the colors of the wires have to be exchanged – red to blue and vice versa.

Input protection for potential-free contact

Either the DM protection or the BDM protection can be used. The nominal voltage is selected according to the reference voltage of the contact. The mechanical contact itself is quite resistant to over-voltage destruction. The protection of the contact is recommended by a lightning arrester in a terminal block DS-B240-RS or DS-B240-RB only in case if contact failure e.g. by welding in case of an arc at surge tip could cause a serious failure.

Fig. 32 Binary input – output, common ungrounded conductor

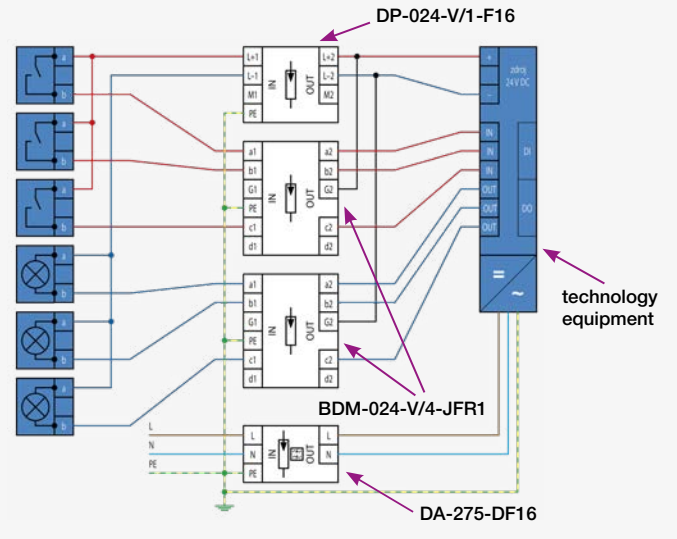
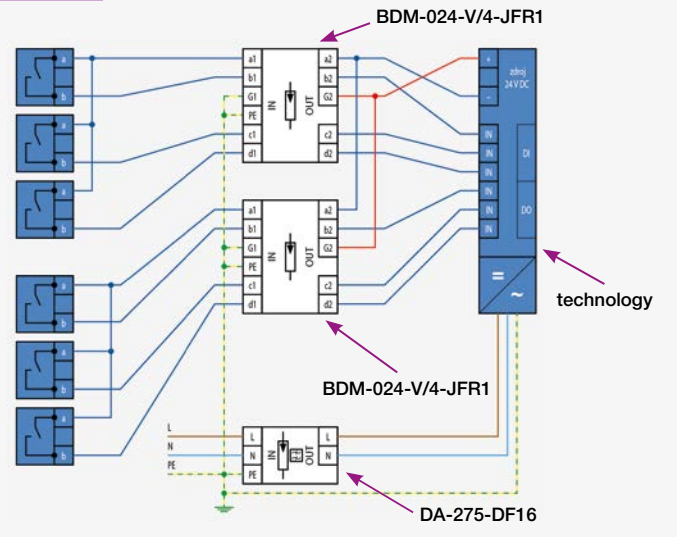
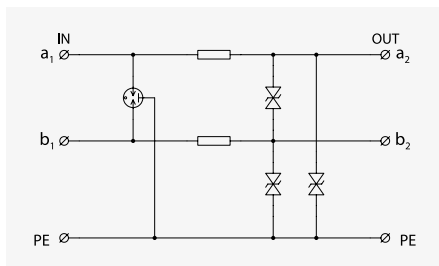

Fig. 33 Binary input – output, common grounded conductor



Connection diagrams

DM-024/1-R-DJ (see Fig. 31)



BDM-024-V/1-FR1 (see Fig. 31)

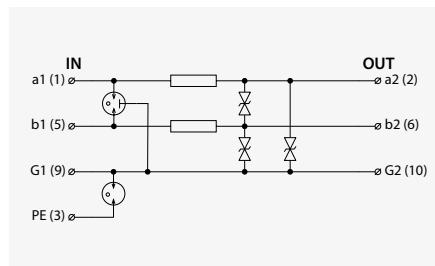

DP-024-V/1-F16 (see Fig. 32)

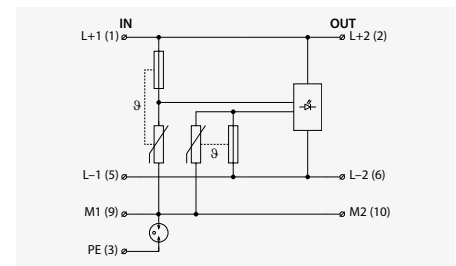

BDM-024-V/4-JFR1 (see Figures 32, 33)

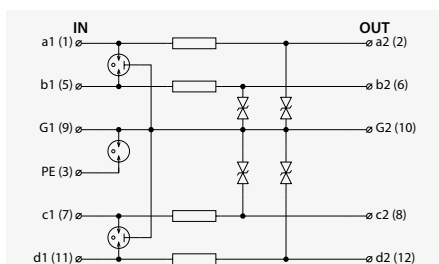

DA-275-DF16 (see Figures 32, 33)

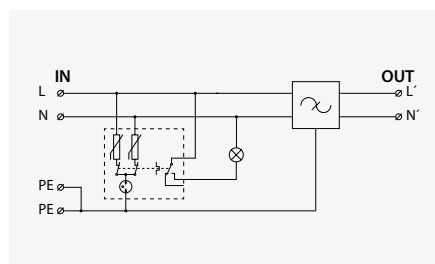

Protection of the sensor with the PNP output is in Fig. 34. The version uses a galvanically separate input, when a dual SPD is more suitable being used. The SPD range DM in the compact design is used in the wiring.

The wiring with SPD with the pluggable module is shown in Fig. 35.

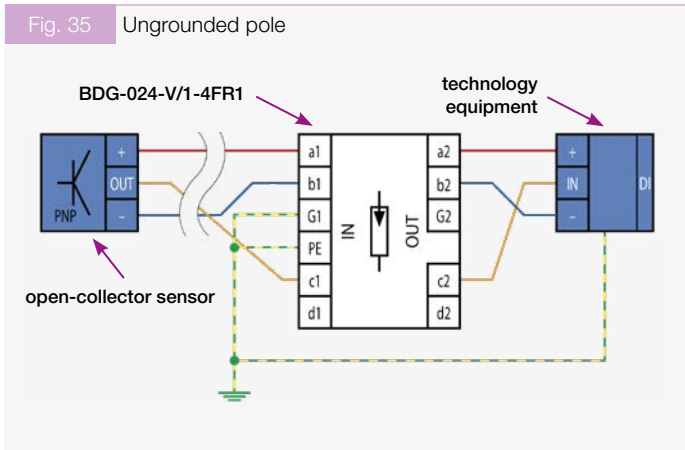
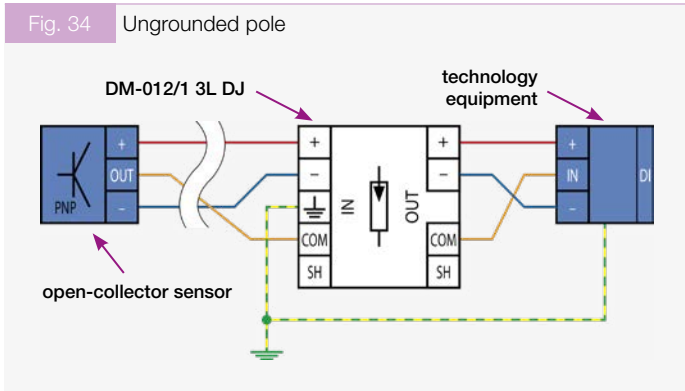

Protection of analog inputs

Analog inputs are more sensitive to the damage by overvoltage than digital inputs. In projects of industrial control systems, inputs for measuring temperature e.g. thermo-elements, resistive thermometers and inputs for universal signals (0-20 mA or 4-20 mA or 0-10 V) are the most common ones. Sensors are often located far from the control system, on different potentials and connected by long lines. In order to reach a sufficient immunity against disturbance, galvanic separation is often used. The breakdown voltage is usually low and even the design of the separator (circuit board) is not designed according to overvoltage protection rules. In any case, additional protection is recommended. An example of a current loop 0-20 mA (4-20 mA) protection is in Fig. 36 in the compact design of SPD and the pluggable version.

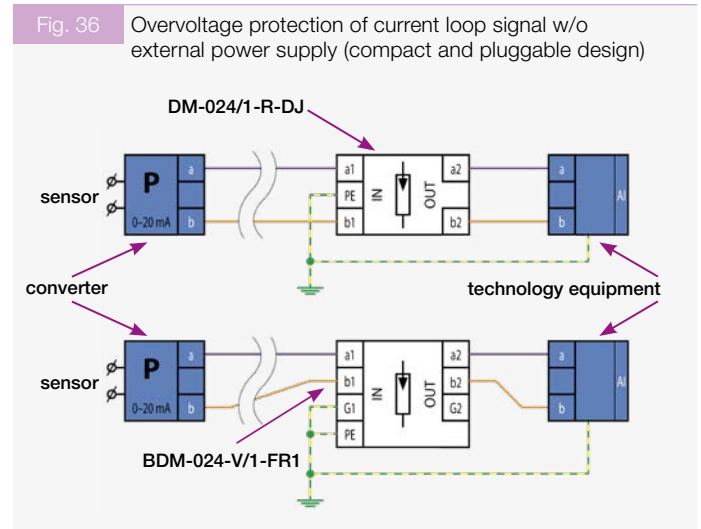

Protection of converters 0–20 mA, 4–20 mA

Due to disturbance immunity, converters with current loop output are often used for remote measurements. In most cases, converters themselves contain electronic circuits and that's why they should be protected. If the device is powered separately from the power network then the internal power source should be protected by SPD type 3 with RF filter.

Connection diagrams

DM-012/1 3L DJ (see Fig. 34)

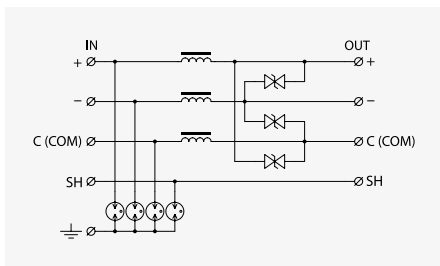

BDG-024-V/1-4FR1 (see Fig. 35)

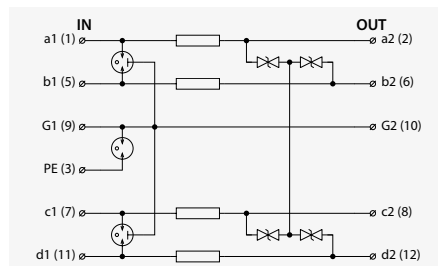

DM-024/1-R-DJ (see Fig. 36)

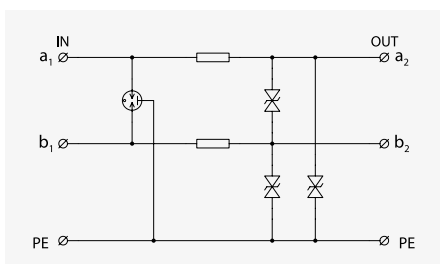

BDM-024-V/1-FR1 (see Fig. 36)

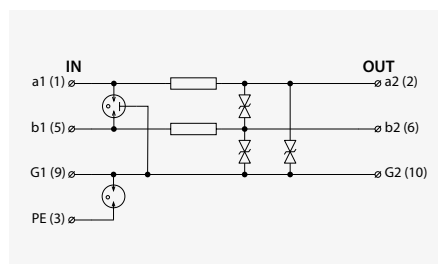

Protection of a current loop, which is supplied from external power source of 24 V DC, is in Fig. 37.

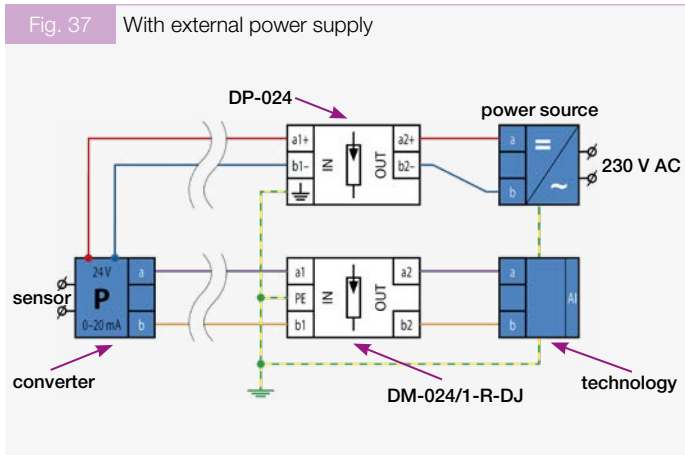

The current loop protection with external power supply and a common wire is in Fig. 38. The protection is realized by a combined (coarse and fine) SPD with pluggable module range DMP.

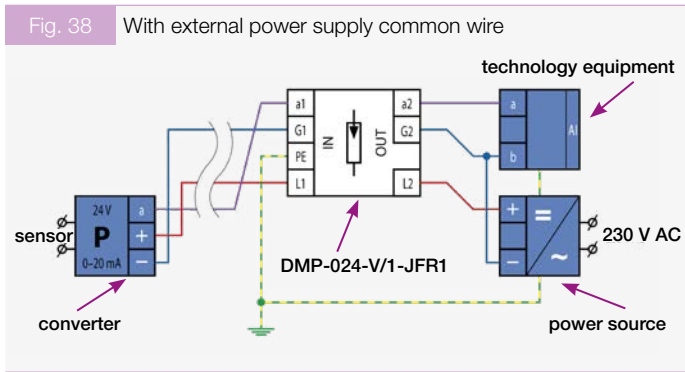

If analog signal communication (0-20 mA, 0-10 V) is exposed to high-frequency interference e.g. electromagnetic field close to the welding machines then SPD for data lines with a low-pass filter is recommended so that all high-frequency components can be

filtered out. For this purpose, special SPD range DMLF should be used. They are available in screw or screw-less design. Connection of these SPDs is in Fig. 39.

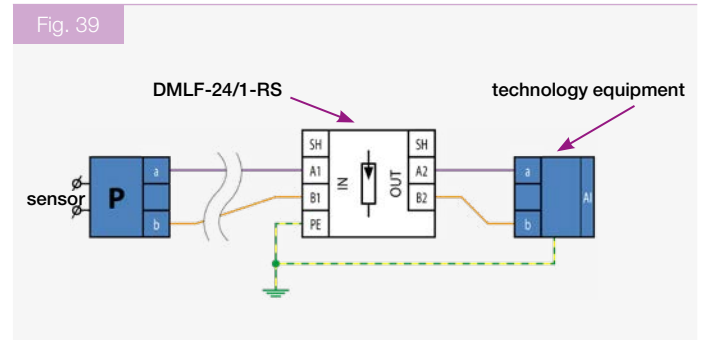

Protection of the thermoelectric cell

Protection of the input for thermoelectric cells is problematic due to the very low range of input voltage that is required for measuring of the thermo-element voltage. Leakage currents and thermoelectric voltage of the protection may negatively influence the measurements. In any case, the protection must be connected behind the terminal block representing the cold junction of the thermo-element. In case the thermo-element has to be protected e.g. due to long lines of the thermo-element near electric machines, an external isothermal terminal block is recommended to be used. The external isothermal terminal block provides the best results in terms of measuring errors. The terminal block should be connected as close as possible to the inputs of the measuring system and then behind it the protection device should be connected.

3.3. Communication bus protection

Communication buses are used to transmit data between different systems. There are many types of communication buses. Fig. 40 shows the implementation of protection of separate devices on the most commonly used RS-485 addressable communication bus, using pluggable version of SPDs for data lines.

Connection diagrams

DP-024 (see Fig. 37)

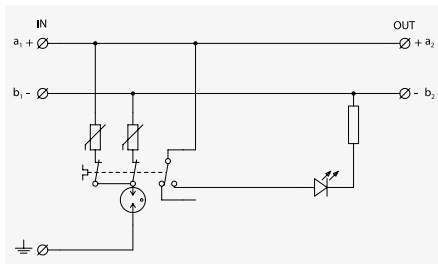

DM-024/1-R-DJ (see Fig. 37)

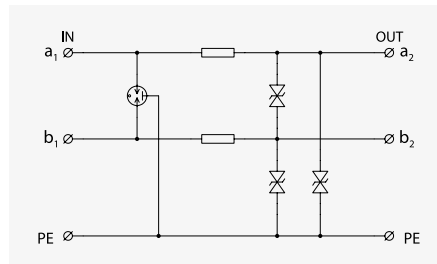

DMP-024-V/1-JFR1 (see Fig. 38)

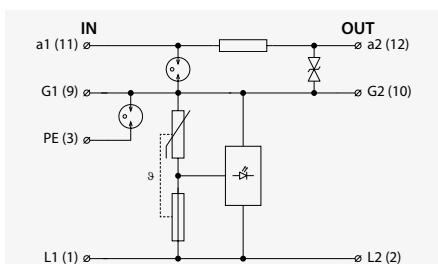

DMLF-24/1-RS (see Fig. 39)

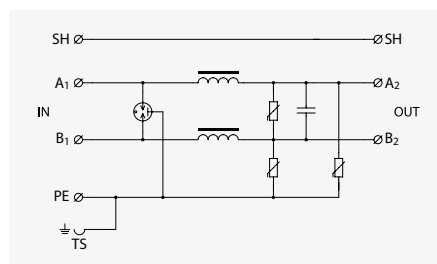

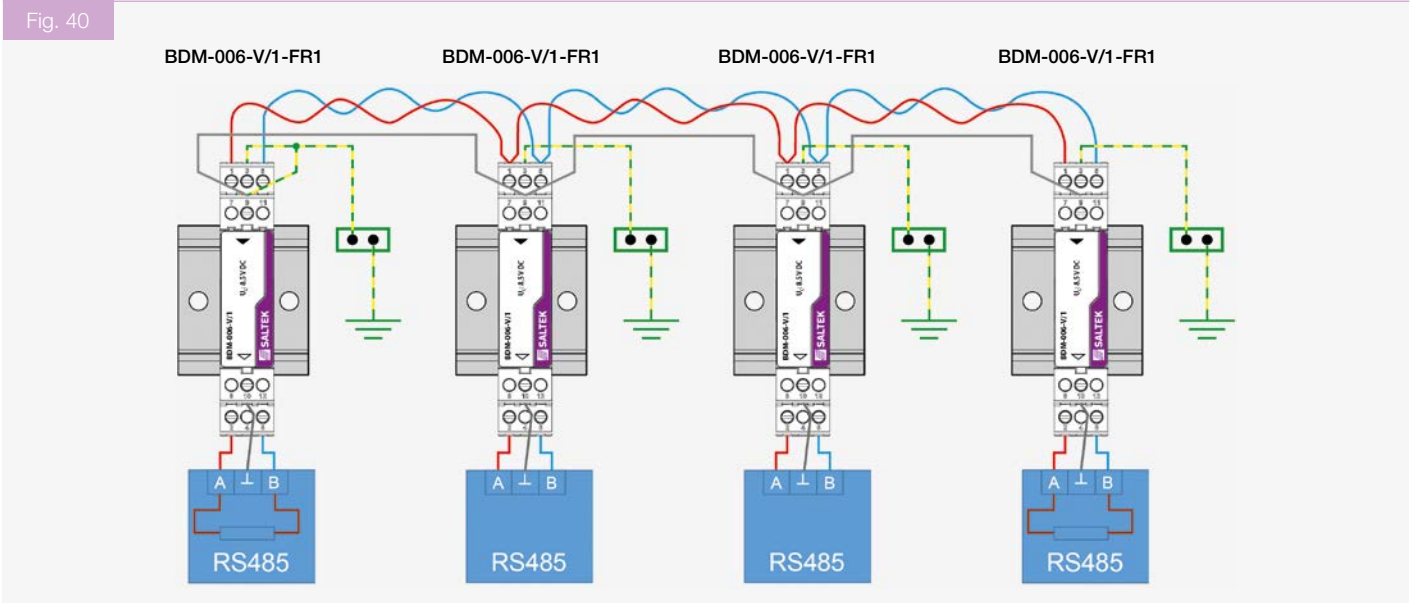

If the shielded communication cable is used, then the shielding on the side of the control system is connected directly to the ground (interconnection of G1(3) and PE terminals of BDM-006-V/1-FR1) and the other devices connected to communication bus should be connected indirectly via the terminal DS-B090-RS or the SPD BDM-006-V/1-FR1 (Fig. 40).

3.4. SPD application in circuits with pulse overvoltage and overcurrents

In industrial environment very often occurs the situations when due to the fault in the electronic circuit (typically it's a shortcut) the power network voltage of 230 V AC can be present on the communication data lines. The shortcut loop has usually high resistivity which isn't enough to trip the circuit breaker connected at the beginning of the power line from which the electronics is supplied. This is why the power line voltage (230 V AC) remains permanently on the electrical equipment impacted by the circuit fault and finally it's dangerous for the human body as well as for the technology equipment itself.

This can be avoided by specialized integrated SPD range DMS-xx x-T. This SPD was designed for DIN rail mounting, and includes a powerful overvoltage protection that repeatedly protects the M&R interface against all types of overvoltage. In addition, the SPD is equipped with special limiters, which disconnect the technology equipment from the exposed line during the presence of the higher voltages than is allowed Fig. 41.



After the fault has been cleared out (i.e. after removing the incoming voltage from line), the device returns automatically to the pass-through state and the measurement, or the data transfer, can be continued without the operator having to intervene.

This special SPD range DMS is mainly used in product pipelines industry for M&R lines, in railways, mines, and other industries where bus lines and M&R lines run in parallel to low-voltage distribution networks, and where a dangerous voltage might be induced in case of a malfunction.

Connection diagrams

BDM-006-V/1-FR1 (see Fig. 40)

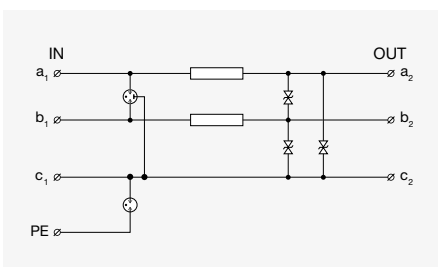

4. Examples of SPD applications – Electronic security/fire alarm systems

4.1. Protection of electronic security/fire alarm/monitoring and access control systems

Security and monitoring systems also include a communication interface. Control units can be equipped with a direct telephone line for automatic alarm reporting, a GSM modem or telephone, or an Ethernet interface for connection to a local area network or the Internet. This allows, for example, remote control, monitoring or viewing of CCTV video anywhere in the world.

The high risk of lightning current injection into the telephone line threatens due to the indirect lightning strike or the strike into the line. Therefore, the overvoltage protection on the telephone line should be designed for lightning currents, especially. According to the type of the line, the SALTEK SPDs in different design ranges CLSA, BD, DL can be used (Fig. 42a, b, c).

Fig. 42a SPD CLSA range



Fig. 42b SPD BD range



Fig. 42c SPD DL range



4.2. Protection in electronic security/fire alarm systems

Protection of input of low-voltage line into the building

A basic power-supply protection at the boundary of zones LPZ 0 and 1, i.e. SPD type 1 and 2. It would be in the main switchboard of the building (type FLP-B+C MAXI V/3). The application is in Fig. 25.

Protection of power supply in main control unit (MCU)

SPD type 3 with an integrated noise suppressing low-pass (RFI) filter installed in the switchboard of the security system – as much close as possible to the protected device. This protection reduces high-frequency disturbance in the network (type DA-275-DF6 or DA-275-DFi6).

In case of a power failure, the MCU is automatically switched to the backup power supply. Therefore, the use of the SPD DA-275-DFix is preferred rather than the standard DA-275-DFx. This type is able to disconnect the MCU from the power supply in case of a failure of the SPD. That way, the MCU is perfectly protected from the subsequent overvoltage pulses that could destroy it. High-frequency disturbance may be very harmful to electronic security/fire alarm systems, and can cause unpredictable system states. Therefore, the disturbance has to be removed if there is a risk of data loss, direct or indirect irreversible damage to property.

Protection of circular loop

The two-stage SPD (ST 2+3) for internal sensor zone loops e.g. motion IR sensors, door and window magnetic sensors, glass break detectors, flood detectors, emergency buttons, smoke and heat sensors, gas leakage detectors, CO sensors, etc. SPDs are installed as close as possible to the MCU e.g. type BDM-024-V/2-FR1. When the zone loop passes from LPZ 0 to LPZ 1, the lightning current arresters (ST 1), e.g. type BD-090-T-V/2-16, should be installed at the entering point to the building. If the sensors or the MCU are located within the distance 5m from the loop entering point to the building (from LPZ 0), then combined three-stage SPD (ST 1+2+3) e.g. type BDM-024-V/1-FR and BDG-024-V/1-FR1 should be installed. Example of the protection of the zone loop inside the object is in Fig. 43a and Fig. 43b.

Fig. 43a Version for loop current up to 500 mA

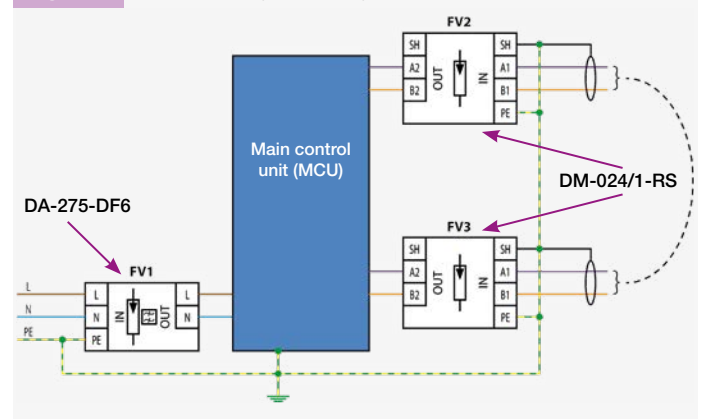
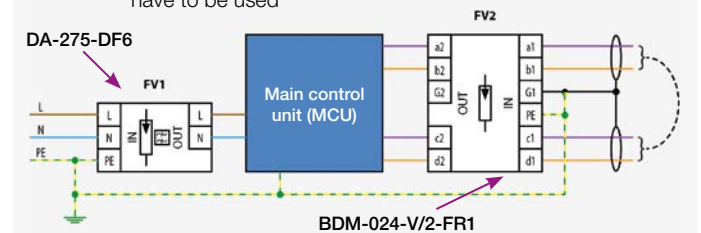

Fig. 43b Version for loop current up to 1 A
For version up to 2 A, two pieces of BDM-024-V/1-FR2 have to be used



Protection of keyboard, tab, operator panel

A combined SPD e.g. the type DMP-012-V/1-FR1 for RS-485 communication line, is installed between the MCU and control interface (keyboard, tab, operator panel, etc.). The SPD should be installed as close as possible to the protected devices on both sides. Example in Fig. 44.

Protection of Ethernet communication line

SPD range DL-Cat.6A is connected between the MCU and local data network/PC/router. The SPD should be installed as close as possible to the protected devices.

Protection of telephone line entering point to the building

A three-stage SPD (ST 1+2+3) to protect the telephone line installed at the building enterign point – type DL-TLF-UHF. The SPD type DL-TLF-UHF has parameters suitable for high-frequency xDSL lines and should be installed as close as possible to the protected device (MCU, phone-line communicator, etc.).

Protection of cameras (e.g. CCTV, IPTV, intercoms)

Three-stage surge protector (ST 1+2+3) for outdoor and indoor IP cameras with Ethernet link and PoE power supply. Installed at the entrance to the building - type DL-1G-RJ45-PoE-AB. For protection of outdoor mounted end devices, the DL-10G-PoE- IP66 weatherproof SPD can be used.

For analog outdoor cameras with coaxial wiring, the lightning arrester (ST 1) FX-090 B75 T F/F (or FX-090-F75 F/F) types are installed at the entrance of the wiring to the building. As a second level of surge protection, a surge protector (ST 2+3) type VL-B75 F/F (or SX-090-F75 F/F) is installed just before the protected equipment.

The VL-B75 F/F surge protector can also be used to protect indoor cameras with coaxial wiring or their recording devices.

The VL surge protector is designed to prevent image interference, which is a common case of image failure in large systems.

For cameras with power supply and control over the RS-485 communication line, the combined surge protector (ST 2+3) for the protection of RS-485 communication line with power supply, e.g. type DMP-xxx-V/1-FR1, is installed close to the protected device.

For transmission of video signal, VL-B75 F/F SPD can be used for coaxial lines, or the DL-Cat.6A SPD for signals transmitted over the UTP/STP cable. The DL-1G-RJ45-PoE-AB or DL-10G-RJ45-PoE-AB can be used for cameras with PoE.

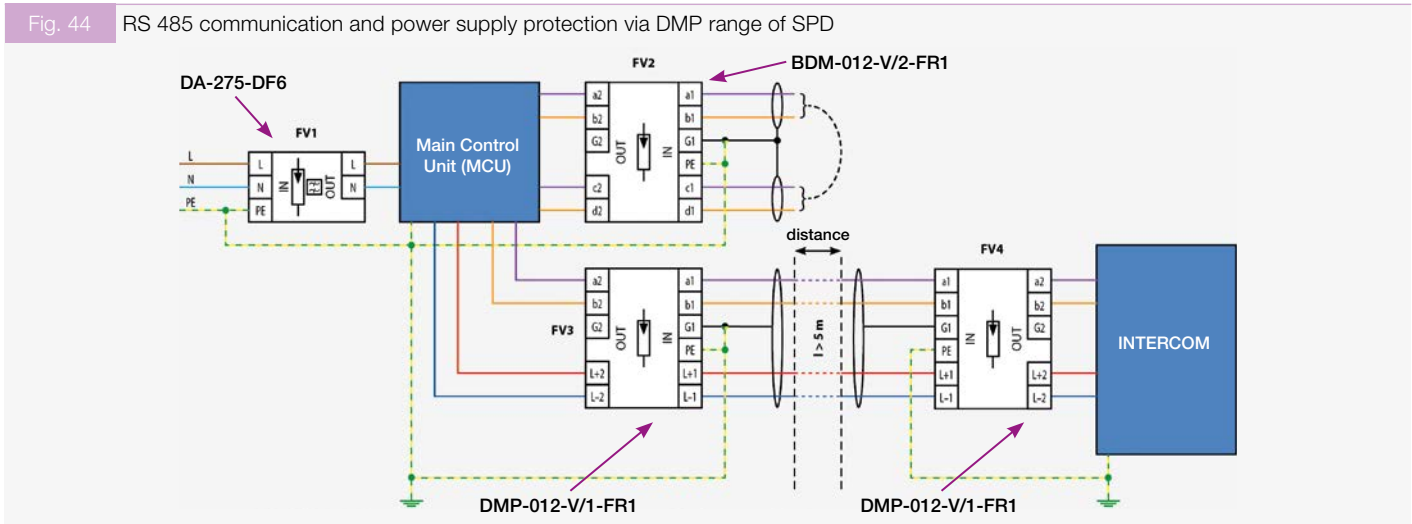

Connection diagrams

DM-024/1-RS (see Fig. 43a)

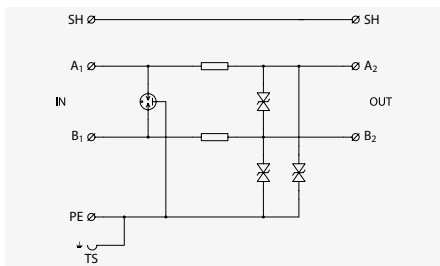

BDM-024-V/2-FR1 (see Fig. 43b)

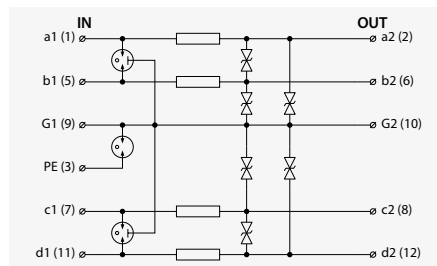

BDM-012-V/2-FR1 (see Fig. 44)

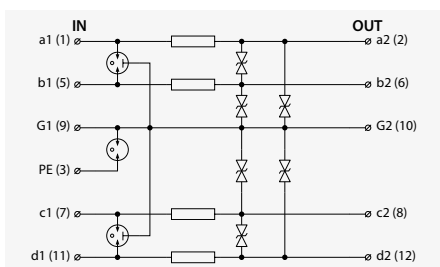

DMP-012-V/1-FR1 (see Fig. 44)

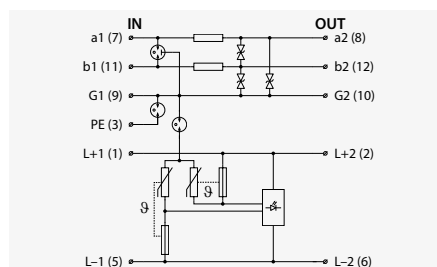
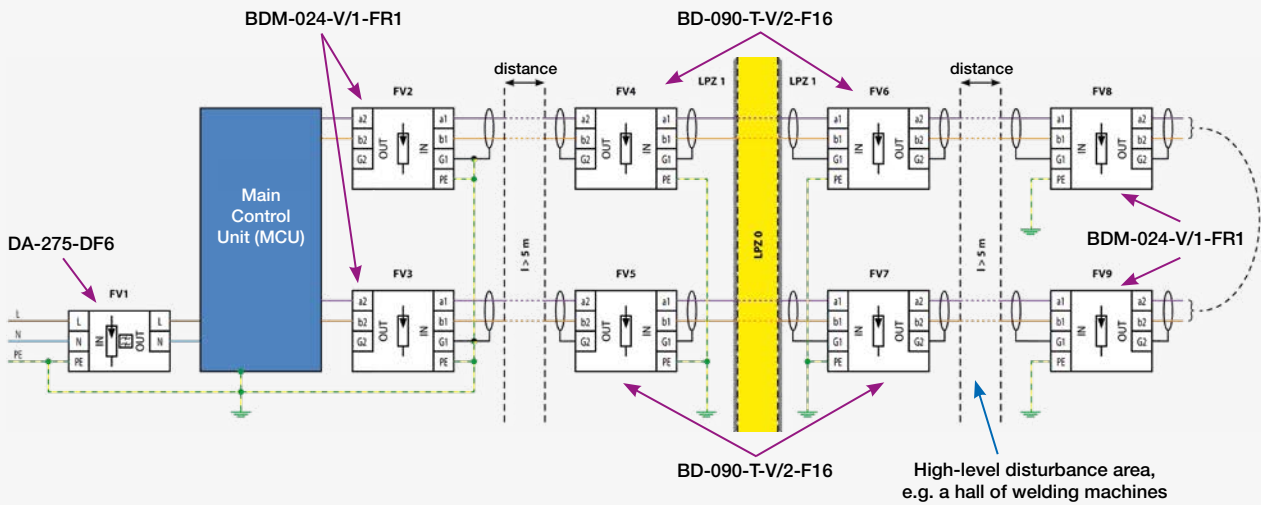

Fig. 45

Solution of protection for crossing between the zones LPZ 0 and LPZ 1
MCU and sensors with a long distance from LPZ 0-1, areas with high level of disturbance



4.3. Examples of protection of communication lines in electronic security systems

4.3.1. Protection of circle line – general case

If the distance of the main control unit from the crossing point of zones LPZ 0-1 is less than 5m then the FV2 and FV4 protections can be changed to a single SPD BDM-024-V/1-FR1 located at position FV2. The same is valid for FV3 and FV5 protections. If the the circle line does not cross a high-level disturbance area in the second building, FV8 and FV9 protections are not needed to be installed (Fig. 45).

4.3.2. Protection of selected communication lines

The Fig. 47, 48 clearly show that the communication lines are very similar each other, and the same type of protection (SPD) can still be used with simple variants in the wiring.

Fig. 46 RS-232 line protection (e.g., DSI programming)

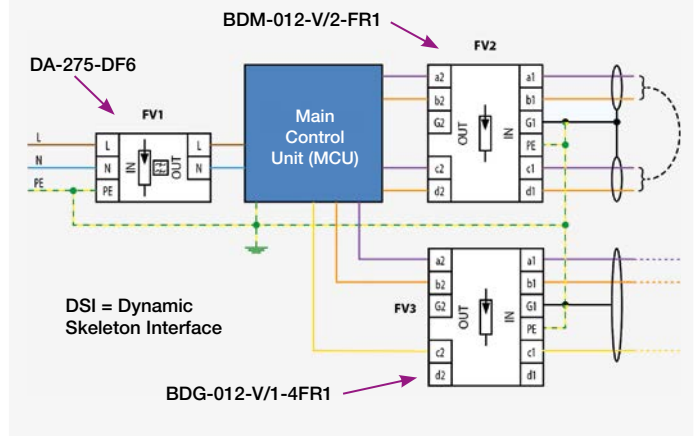

Connection diagrams

BD-090-T-V/2-F16 (see Fig. 45)

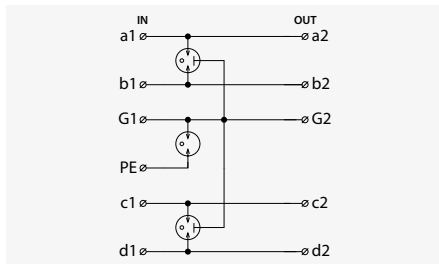

BDM-024-V/1-FR1 (see Fig. 45)

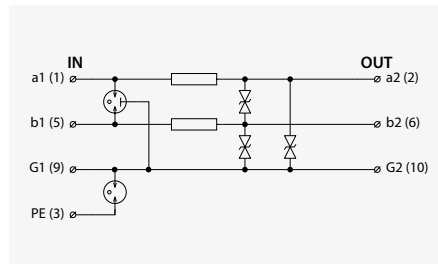

BDM-012-V/2-FR1 (see Fig. 46)

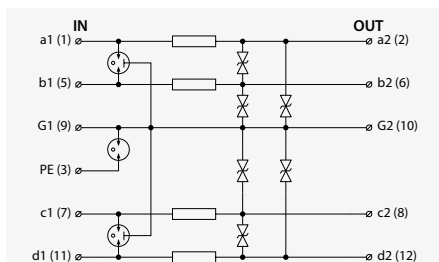

BDG-012-V/1-4FR1 (see Fig. 46)

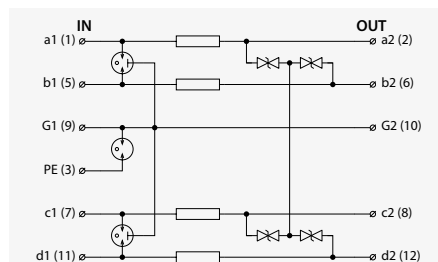

Fig. 47 Protection of Intellibus – designed to connect the Ethernet module and the module of PIR cameras

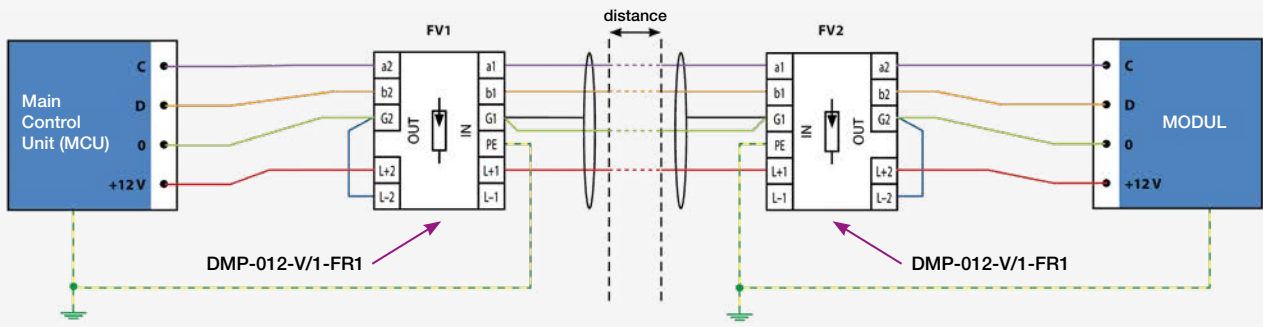

Fig. 48 Protection of RS-485, e.g. main control unit GALAXY

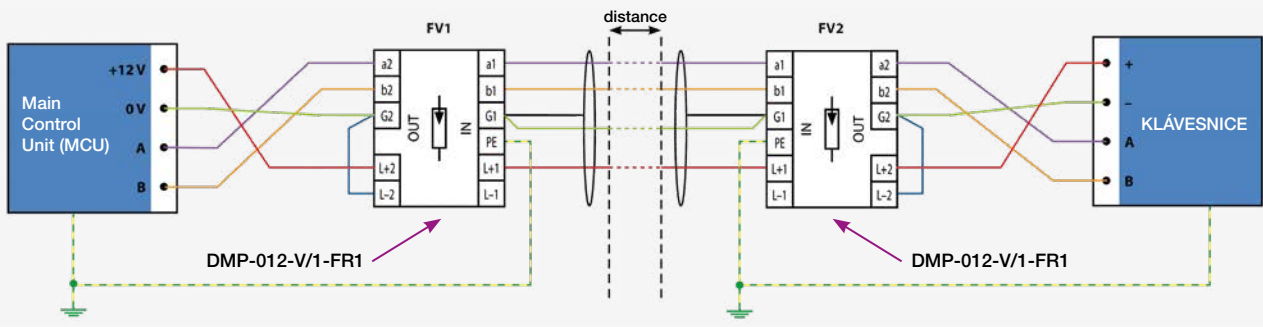
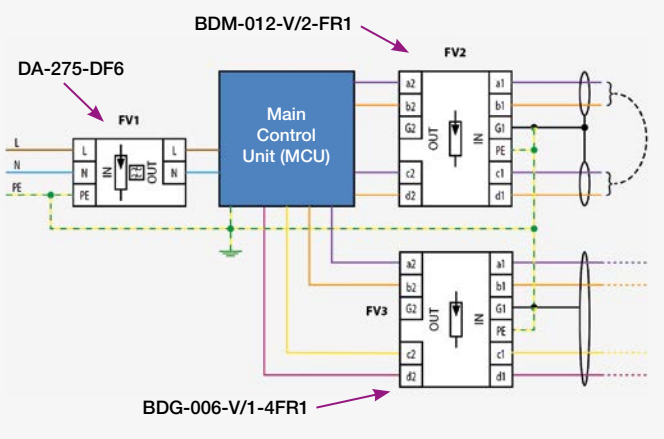
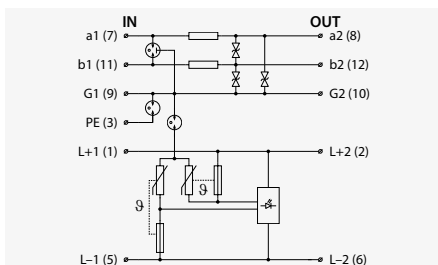

Fig. 49 Protection of IB 2 communication



Connection diagrams

DMP-012-V/1-FR1 (see Figures. 47, 48)



BDG-006-V/1-4FR1 (see Fig. 49)

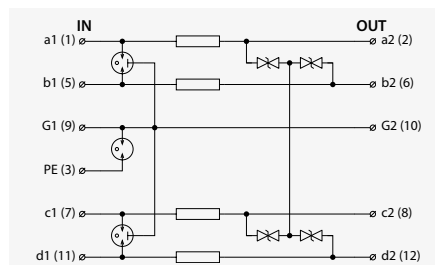

BDM-012-V/2-FR1 (see Fig. 49)

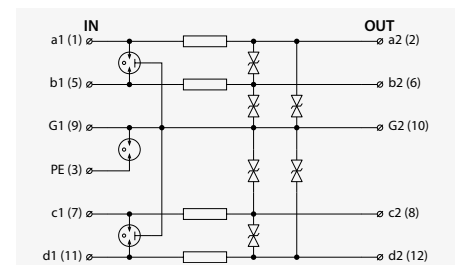

5. Protection of ICT networks and structured cabling - Ethernet

Ethernet networks are the dominant communication infrastructure of information and communication technologies (ICT), and has become an indispensable part of nearly all human activities nowadays (industry, telematics, automation, science, healthcare, entertainment, ...). Any interference on the network always means a serious threat to production, communication, safety, health etc., and is accompanied with the occurrence of considerable damage. One should bear in mind that Ethernet signal is a high-frequency multiple-level signal (5 levels with 1G Ethernet and even 16 levels with the 10G Ethernet) with a small amplitude, where the difference between the individual levels (which is the key feature for taking decision about accurate reading in of digital information) is in the order of hundreds of millivolts, and the length of transmitted symbols varies within the order of units of nanoseconds. Overvoltage pulses with voltage levels sometimes achieving the value of kilovolts, subsisting for a period of hundreds of microseconds, significantly damage the transmission of data and represent a danger to the physical interface between the network elements. That is why it is necessary to eliminate them to the highest possible extent.

5.1. Protected parts and placement of SPD

5.1.1. Active elements of the network

Servers, switches, control PCs, PTZ or IP cameras etc. are the key parts of an ICT network (most often linked with a high purchase value) and serve as a transmission means for data and, at the same time, provide for the system intelligence (software). These elements, most particularly, need to be protected. The overvoltages, disturbances and harmful impulses may enter the system mostly from the connection side, i.e. from the point where data and power supply cables are connected to, or via the mechanical structure. When designing the protection this is the general protection criteria which have to be met in the first rank, which can be achieved by:

- **Proper location of the equipment to be protected**

- Placing the outdoor equipment (antennas, cameras, sensors, ...) into the LPZ 0_b zones. If the zones are not available, then they need to be created wherever it is possible (i.e. the erection or revision of lightning protection system).
- Placing the control equipment (data centres, PCs, PLCs, switches, PBX, ...) into the LPZ 2 zones.

- **Equipotential bonding of the equipment to be protected**

- Installation of equipotential bonding bar and connecting all the (electrically conductive parts of) protected equipment to the bar using shortest possible conductors with a proper gauge (cross-section).
- Establishing proper interconnection and its protection among buildings (objects)

- **Using special protective elements against pulse-shaped overvoltages (SPDs)**

The protection is done by inserting the **SPD of the DL series** (connected in series) into the Ethernet cabling. The installation place of the SPD is to be chosen depending on the protected equipment, i.e.

- **As close as possible to the important element of the network** (server, switch, camera, access technology (AP), telephone exchange, ...)
- In between the data switchboard (RACK) and the PC, camera control unit (CCU) ...
- **At the input/output into/from the building/object** (on the borderline of LPZ 0 and LPZ 1 zones) – protection against the propagation of overvoltage impulses into the building

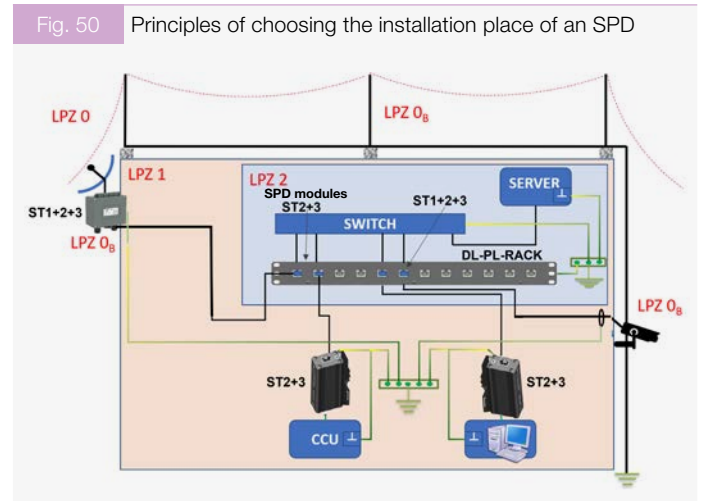

It is necessary to protect the equipment both on the data line side, but also on the power supply side. In this context all the **principles of LV power supply line protection** (AC and DC), as described in previous sections (section 2) apply, i.e. the LV distributions need to be protected with three-stages of protection (FLP+SLP+DA with HF filter).

5.1.2. Cables used in the Ethernet network/ structured cabling

Since 1980 the data traffic speed at the Ethernet network significantly increased and the originally used coaxial cables for data transmission have been replaced with structured cabling systems based on metallic (twisted pair) conductors but also fibre optic cables. Older networks with data transmission capacity of 10 Mbps/s to 100 Mbps/s (the so called Fast Ethernet) currently shift to speeds from 1 to 10 Gbps/s, even on local area networks (LAN). The reason for this speed increase consists in the ever increasing volumes of transmitted data, the transmission of video and TV signals, signals for automated control units, etc. Sophisticated, structured Ethernet network technologies have to meet the ever increasing transfer speeds and have to cope with also other signal types (such as the powering, various voltage levels of analogue and digital signals, ...), which makes them susceptible to various types of disturbances. The most frequently used passive element in a structured Ethernet network is the twisted pair cable (UTP – without shielding; FTP/STP/SSTP/S-FTP-shielded) used as a transmission channel for both data and also other signals running between the active elements of the network. Depending on the data throughput rate the cabling can be divided into categories (Tab. 1). The lines are usually terminated with RJ45 connectors (or GG45 and others, starting from CAT 7 and higher) which provide for easy interconnection to other LAN elements (Fig. 52). When choosing the cabling category and the related equipment (including the SPDs) it is necessary to consider **both the current and the expected demands on the infrastructure in the future, during the whole service life of the system**. The demands on transmission capacity are increasing exponentially with the time.

When protecting the cables we strive to **prevent the entry of an overvoltage** to the active LAN elements via **Ethernet cables**. For this reason we install the SPDs primarily **at the place where the cable enters the building** (boundaries of LPZ 0 and LPZ 1 zones). Ethernet cabling is usually tested with insulation voltage of approx.

Table 1 – Categories, data throughput and cable usage

CAT	Throughput	Protocol	Bandwidth	Use
3/4/5	≤100 Mb/s	10BASE-T 100BASE-T	16 - 100 MHz	Old data distributions (ISDN, Token Ring, telephone lines,...). Not recommended for use in newly installed networks.
5e	≤1 Gb/s	1000BASE-T	100 MHz	Currently the most frequently used category for IP networks. Not recommended for new installations and PoE++
6	≤1 Gb/s (10 Gb/s max. length 50 m)	1000BASE-T	250 MHz	New data networks for which the capacity expansion in the future is not being foreseen, and with a service life which expires within 5 years, residential construc- tions , distributions with PoE++
6A	≤10 Gb/s	10GBASE-T	500 MHz	New networks for ICT (data, video, voice, security, ...); currently a standard for data centres, commercial building constructions, hospitals, university campuses, ... PoE++ with expected service life of 10+ years
7	≤10 Gb/s	10GBASE-T	600 MHz	New networks for ICT, in particular networks susceptible to disturbances and cross-talk (double screening), more services running on one cable (voice, data, TV, ...).
7A	≤10 Gb/s	10GBASE-T	1 000 MHz	New networks for data and video signals, CATV running at 862 MHz, MULTIME- DIA, distributions with ever increasing data transmission capacity in the future (15 and more years.)
8	≤40 Gb/s (max. 30 m)	25GBASE-T 40GBASE-T	2 000 MHz	High-speed backbone interconnections not exceeding 30m (e.g. the patch panels, etc.).

1 kV. Overvoltage pulses, however, may attain the multiple of kilovolts and, without correctly selecting and properly locating the SPDs, the overvoltage may even mechanically damage the cabling. Searching and troubleshooting of these types of defects, in particular within a structured cabling, is time consuming and expensive. **The protection of data transmission cables may at best be achieved by choosing SPDs of the DL type series, connected (in series) into the Ethernet line (see section 5.3).**

Fig. 51 Categories, data throughput and cable usage

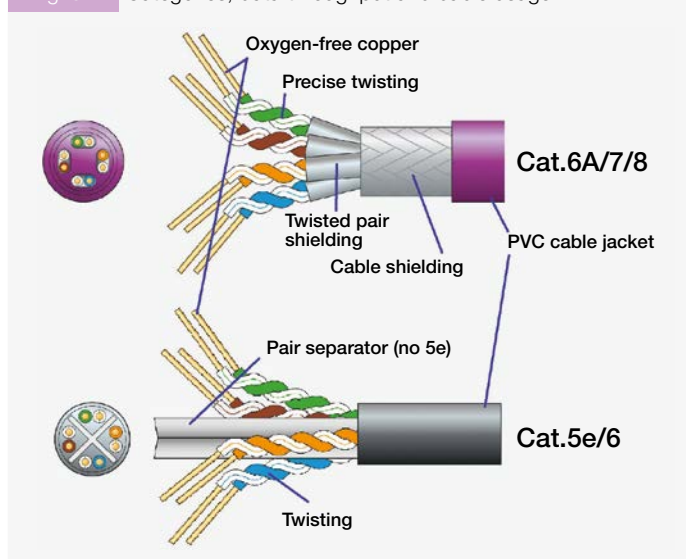
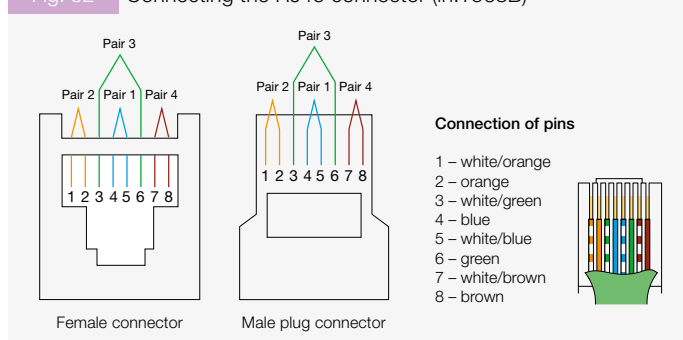

Fig. 52 Connecting the RJ45 connector (in.T568B)



5.1.3 Power supply lines and PoE

The powering of active elements at the network and provision of power supply to PDs (Powered Devices = powered terminal devices such as an IP camera) is ensured by energy taken out from LV mains (public power supply, own power generators, UPS, inverters) and/or by DC power supply units connected via cables to the powered equipment (from a battery, DC power source,...), which often are laid in cable routes together with data cables. In this case the protection from overvoltage is similar to that of the LV power distributions, i.e. by using multistage protection installed on the boundary of the LPZ zones, namely in the main LV switchboard (T1 or T1+T2), and in secondary LV switchboards (T2). Regarding the active LAN elements – these should be protected with fine protection of the T3 class, installed as closely as possible to the protected element.

Table 2 – List of various types, standards and capacities of PoE

Type	IEEE standard	Power consumption of PD	I_L /pair	Pairs for PoE	Use
1-PoE	802.3af	13 W	350 mA	1 / 4	= 802.3at type 1 / IP telephony, wireless access points (AP)
2-PoE+	802.3at	25,5 W	600 mA	1 / 4 opt.A 2 / 3 opt.B	= 802.3at type 2 / surveillance cameras, GSM femtocells, ...
3-PoE++	802.3bt	60 W	650 mA	1 / 2 / 3 / 4	PTZ, camera heating, MW communications, GSM picocells, ...
4-PoE++	802.3bt	100 W	1 000 mA	1 / 2 / 3 / 4	LED lighting, videoconferences – large screens, building control systems, information kiosks, ...

Due to the vulnerability of LAN networks to disturbances it is recommended to use T3 protections with built-in low-pass filter to prevent the propagation of HF disturbances along LV (or DC) lines into the protected equipment and also from the equipment to the outside.

In order to simplify the networks and to reduce the investment costs, the technique of line sharing started to be used since 2003, which proved to be beneficial also for the power supply needs of end user equipment connected to the Ethernet network – the so called PoE (Power over Ethernet). The ever increasing power consumption needs of end user devices was accompanied with the development of new modes and the increase of power supply capacity of the PoE. Power supply to PDs is provided by either some selected network elements (e.g. the PoE Switch or Hub) or special PoE injectors (simple passive or intelligent active components) powered from a suitable source (PSE – Power Sourcing Equipment). The PSE usually provides power with voltages ranging from 44 V to 58V (most often 48V).

The “at” standard defines two types of PoE+: type A = power supply via 1-2 and 3-6 pairs; type B = power supply via the 4-5 and 7-8 pairs. The “bt” standard uses all 4 data pairs for the provision of power supply.

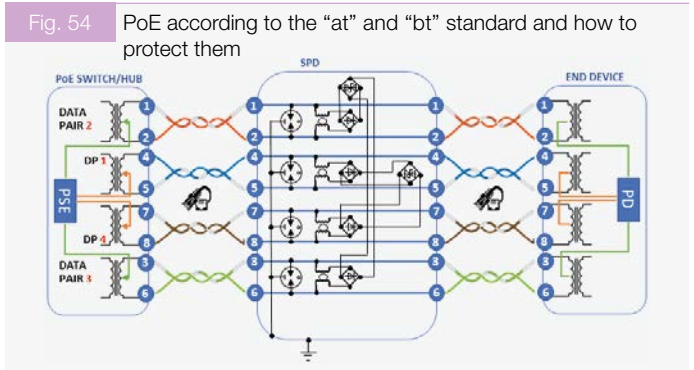
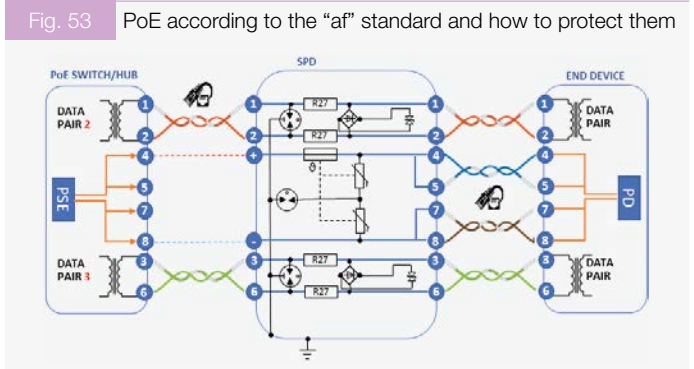

Table 3 – Main causes of interferences, disturbances and risks involved

Cause of disturbance	Penetration into ICT	Risk	Elimination
Direct lightning strike	Arc flashovers	Insulation breakthrough	Properly designed and installed lightning protection system (LPS);
	Propagation via cables	Physical destruction, data loss	Installation of 3 stages of protection (FLP+SLP+DA) into the power distribution line; separation of power supply and signal cable routes
	Induction into data cables by the effects of electromagnetic fields caused by lightning strike currents	Physical destruction, disturbances / data loss	Installation of an SPD into the data line: <ul style="list-style-type: none"> ■ as close as possible to the protected equipment ■ on the borderline of the LPZ (in particular 0-1) Keeping proper distance (or using cable screening) of the cabling from nearby lightning conductors. Minimization of cable loops with the effect of inductive coupling reduction, thereby resulting in the decrease of pulse voltages.
Indirect lightning strike (occurring at a distance within approx. 3km)	Induction of electromagnetic fields into power supply and data cables and into current-conducting structures	Physical destruction of the equipment, disturbances / data loss	Installation of 3 stages of protection (FLP+SLP+DA) into the power distribution line; separation of power supply and signal cable routes. Installation of an SPD into the data line: <ul style="list-style-type: none"> ■ close the equipment to be protected ■ on the LPZ borderline (in particular 0-1) Minimization of cable loops with the effect of inductive coupling reduction, thereby resulting in the decrease of pulse voltages.
Pulse interferences coming from the MV/ LV power distribution network	Via power supply cables	Physical destruction of the equipment, disturbances / data loss	Installation of 3 stages of protection (FLP+SLP+DA) into the power distribution line; separation of power supply and signal cable routes.
Industrial interference – LF load switching impulses, thyristors,...	Via power supply cables, induction into data cables	Physical destruction of the equipment, disturbances / data loss	Installation of fine protection stages (SLP+DA) into power supply distributions; severing the power supply and signal cable routes; using SPDs with low-pass filters in power distributions.
Industrial interference – HF pulses + noise caused by inverters or welding machines	Induction of electromagnetic fields into cables; interference propagation along power supply conductors	Drop out of service, high failure rate, data loss	Installation of fine protection stages (SLP+DA) into power supply distributions; severing the power supply and signal cable routes; using SPDs with low-pass filters in power distributions; electromagnetic shielding of cables and technological equipment (installation into metallic troughs; physical separation of LV power supply and signal cables)

Table 4 – Selection chart of SALTEK SPD protections for Ethernet installations

Protected ICT technology	Basic type of SPD	Model RACK	Support PoE/+/++	SALTEK classification	Installation place of the protection
Ethernet only	DL-Cat.6A	DL-Cat.6A-M (-R-M)	X/X/X	ST 2+3	As close as possible to the protected equipment – PC, Switch, Hub, IP camera,...
Structured cabling in general (data, signals upto 58V _{pp} – i.e. IP phones with ring, M&R,...)	DL-1G-60V-PoE DL-10G-60V-PoE	DL-1G-60V-PoE-M DL-10G-60V-PoE-M	A/A/A	ST 1+2+3	Borderline of LPZ (0-1) zone – against the propagation of interference signals into the object; as close as possible to the protected equipment – Switch, Hub, Server,...
Ethernet; Ethernet + PoE	DL-1G-RJ45-PoE-AB DL-10G-RJ45-PoE-AB DL-10G-PoE-IP66	DL-1G-PoE-M DL-10G-PoE-M	A/A/A	ST 1+2+3	Borderline of LPZ (0-1) – against the propagation of interference signals into the object; as close as possible to the protected equipment – Switch, Hub, Server,...
	DL-Cat.6A-60V	DL-Cat.6A-60V-M (-R-M)	A/A/A	ST 2+3	as close as possible to protected technology
Fast Ethernet + PoE (Cat.5e)	DL-Cat.5e POE plus	no	A/A/X	ST 2+3	As close as possible to the protected equipment – PC, IP camera, Switch...
PoE (injector with integrated SPD)	DL-1G-POE-INJECTOR	DL-1G-POE-PCB-INJECTOR	A/A/X	ST 1+2+3	As close as possible to the protected equipment – Switch, Hub, Server, ...

* passive injection

Other types of PoE systems can also be encountered on the market, most frequently the UPoE and PoH. Basically, the proprietary UPoE from Cisco is in principle a combination of the A and B types of “at” standard, which uses all 4 pairs for the supply of 60W power to the end devices (supported e.g. by Cisco Catalyst 4500E switches). In professional networks used for the transmission of HD/UHD video signals we can find the so called PoH, which provides 100W of power via 4 cable pairs in networks using the HDBaseT protocol. Both the above systems can be protected by the same type of protection as being used for the four-pair “bt” systems. **Regarding the protection of power lines with PoE we choose SPDs from the table in section 5.3, taking account of the transmission speed and the transferred PoE power.**

Attention! The powering voltage on PoE is ranging usually within 44 V to 58 V. The connection of power sourcing equipment (PSE – such as the PoE switches, etc.) via cable to the SPD, which however are not intended for PoE transfer (i.e. having $U_c \leq$ of approx. 58V) may lead to an unwanted reaction of the SPDs and cause a malfunction (short circuit of PoE and other effects)!

Fig. 55 Earthing of a long shielded cable / bundle / cable duct / cable trough

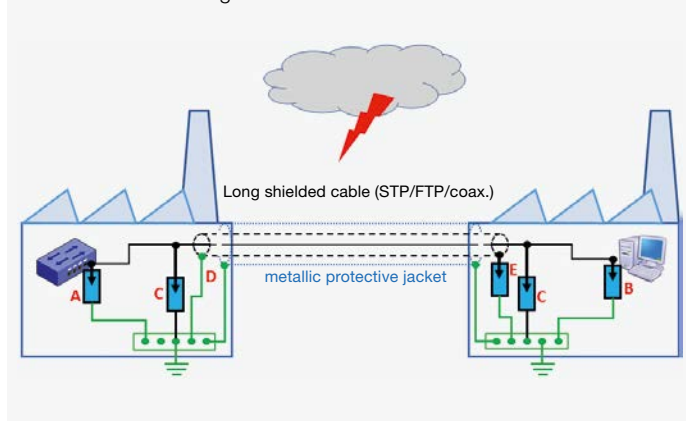
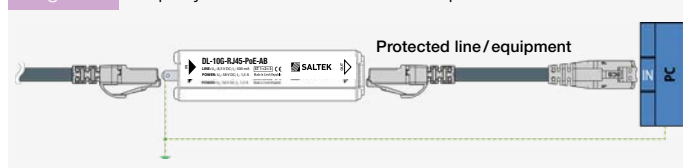

Fig. 56 Properly oriented SPD for efficient protection



5.2. Causes of disturbance, risks and their elimination

Basic prerequisites for the design and the installation of Ethernet networks (from the point of view of protection against overvoltage impulses and interferences):

- Protection of an object from lightning strike and static discharges (properly designed and earthed lightning conductor; creation of LPZ 0_B protective zones for the installation of antennas, air conditioning units, ...).
- Installation of a terminal bar (PE/PEN) for protection by equipotential bonding (cable racks, electrically conductive cabinets, ...).
- Rigorous utilization of multi-stage SPD protections on power supply lines (see the LV part) and signal lines.
- Prevention of induced currents from lightning conductors (minimization of cable induction loops and conductors running in parallel, keeping adequate distance between the installed equipment and the lightning conductor).
- Separation of power supply and data lines (shielded and not shielded cables / bundles) – spatial separation, shielding to prevent crosstalk arising in cable troughs – see also section 1.6).
- Usage of shielded cables and earthing the shielding on both ends (see Fig.55: A, B = equipment protection; C = protection from the propagation of overvoltages/ interferences into the building; D = electrically conducting earthing; E = indirect earthing via SPD there, where a different electric potential between the various equipotential terminal boards may be assumed – separation between the buildings, long cables,...). If screened cables are laid across the LPZ 0 zone (e.g. mounted on overhead structures between the buildings), it is necessary to place the cables into metallic protective jacket earthed on both ends (see also section 1.6.4.).

- **Prevention of laying power supply distribution conductors in parallel with other (signal/data) cables** (induction of overvoltage peaks from the distribution mains).
- **Use separate cables from each other that lead to end terminals provided with individual SPD protection** (long connection wires, bushings between the LPZ zones, in particular from/into the LPZ 0 zone).
- **Usage of encapsulated electrically conducting cable ducts / cable troughs in zones with strong electromagnetic fields** (situated near radio transmitters, base transceiver stations (BTS), transformers, switched power supplies, ...) **where electro-optical signal converters cannot be used.**
- **Relocation of sources of interference** (lift machinery rooms, voltage changers, converters, radio transmitters, transformers, ...) **where feasible, as far away as possible from the ICT networks, or providing them with electromagnetic shielding.**
- **Replacement of metallic cables with fibre-optic cabling when bridging of long paths is to be established (between distant buildings, to remote equipment, ...).** Attention! Cables with metallic screening or armouring are subject to all the protection regulations and rules concerning the installation of SPDs to apply for long conductors/screening (see Fig. 55) !!! Optical converters may be protected similarly to other Ethernet equipment, including their power supply systems.
- **Proper location and orientation of the SPD** – the IN port must be connected to the line on which the arrival of pulse overvoltage can be expected. The OUT port shall be connected to the line leading to the protected equipment, regardless of the flow direction of the signal/data (note: some of the SPDs have the IN port marked with thick arrow, the OUT port with double empty arrow)

5.3. Choosing the SPD protections for Ethernet networks

When choosing the SPD protections for mounting into the Ethernet networks or structured cabling, the following is to be taken into consideration:

- Type of transmitted signal
 - If **only Ethernet signals** (data) are transmitted, then an SPD with the lowest UP protective level between the pair wires should be chosen, where the difference between the highest amplitude of usable (wanted) signal (in Ethernet it is $\pm 1V$ to $\pm 2V$ max.) and the level at which the SPD starts to limit the overvoltage peaks should be as low as possible (e.g. **SALTEK DL-Cat.6A, DL-1G-RJ45-PoE-AB**).
 - If SPDs are used in systems with **general structured cabling**, it is to consider what type of signal may be connected to such a cabling and based on the considerations to choose the correct type of SPD (with appropriated UP level). In structured cabling systems, where e.g. the connection of phone lines with 48 V and higher voltages on one conductor pair can be assumed, an SPD with the corresponding highest permanent operating voltage between the conductors should be used (e.g. **SALTEK DL-10G-60V-PoE** or DL-1G-60V-PoE or DL-Cat.6A-60V).
 - If the cabling is to be used also for **powering (PoE)**, then a type SPD should be chosen which has its protective elements connected not only between the conductors of pairs (protection of signal line), but also in between the pairs used for the transmission of power (PoE – protection of power supply line). The majority of SPDs on the market and denoted as “PoE protections” provide only a rough PoE protection (spark gap), which often is

not being able to adequately protect the PSE, as the UP protective level between the cores in this particular execution is of the value about 500V (!). In order to provide highest possible protection for the PoE technology SALTEK has developed a special series of SPDs which is able to protect both the signal lines (within the pairs as such), but also the PoE ports (in between the pairs). The typical product for this application is SALTEK DL-10G-RJ45-PoE-AB (or its version DL-1G-RJ45-PoE-AB).

- Transmission capacity (transmission speed)
 - Up to 1 Gbps (SPD SALTEK of DL-1G-... series)
 - Above 1 Gbps (SPD SALTEK of DL-Cat.6A-... and DL-10G-... series)
- Installation place of the protection
 - Inside the building – SPD protections of T2 and T3 type
 - Outside of the building or on the boundary-line of the LPZ 0 and LPZ 1 zones (line entry into the building) – SPD protections of the T1+T2+T3 type

Fast selection

If you want to avoid any uncertainty when choosing an SPD, while nevertheless to be sure that you have chosen a general-purpose protection to cope with the highest possible current and future usage demands of an Ethernet network, we can recommend you the following:

Ethernet cabling = only data, without PoE	DL-Cat.6A
Ethernet cabling with PoE = data + any type of PoE	DL-10G-RJ45-PoE-AB
Structured cabling in general = Ethernet data + PoE, KNX, RS-485 + signals with voltage levels up to $58V_{pp}$	DL-10G-60V-PoE
Outdoor Ethernet technology with PoE	DL-10G-PoE-IP66

SALTEK RACK system

The most of the above mentioned protections are also available as modules which make the installation of SPDs in server rooms easier and more efficient. The modules are designed for to be built-in into 1U unit (see Fig. 57,58 - the RACK column). By combining the SPD modules it is possible to put together packages specifically tailored to the customer needs. The assembly in 1U spares the installation place in the rack, makes the cabling easier and allows

the SPDs to be concentrated for various categories of cabling or active protected equipment and allows the installation of up to 16 SPD modules in one 1U box. The ground connection of the SPDs takes place in the inside of the 1U box. The combination of the SPD modules is highly flexible (concerning the selection see the Fig. 9) and can be easily extended to cope with the future technological developments.

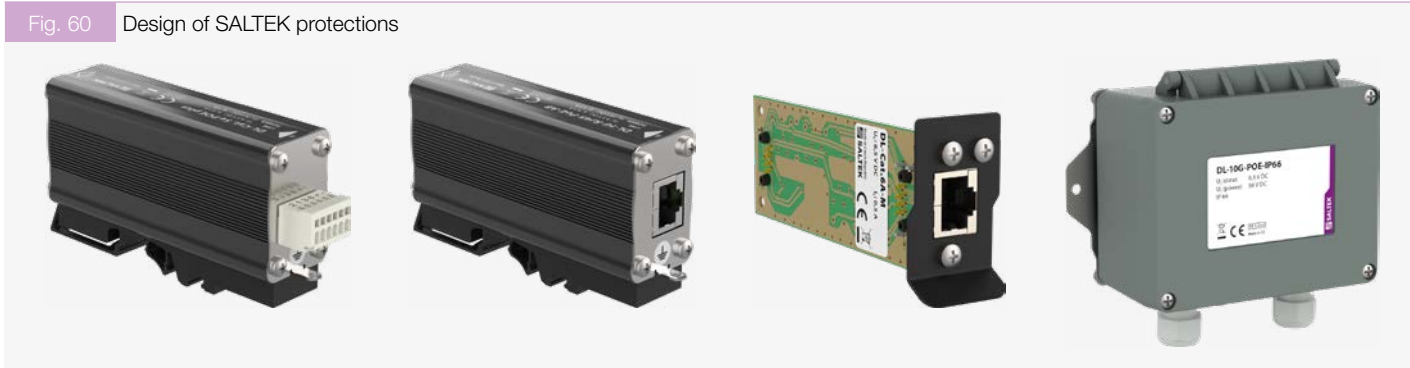
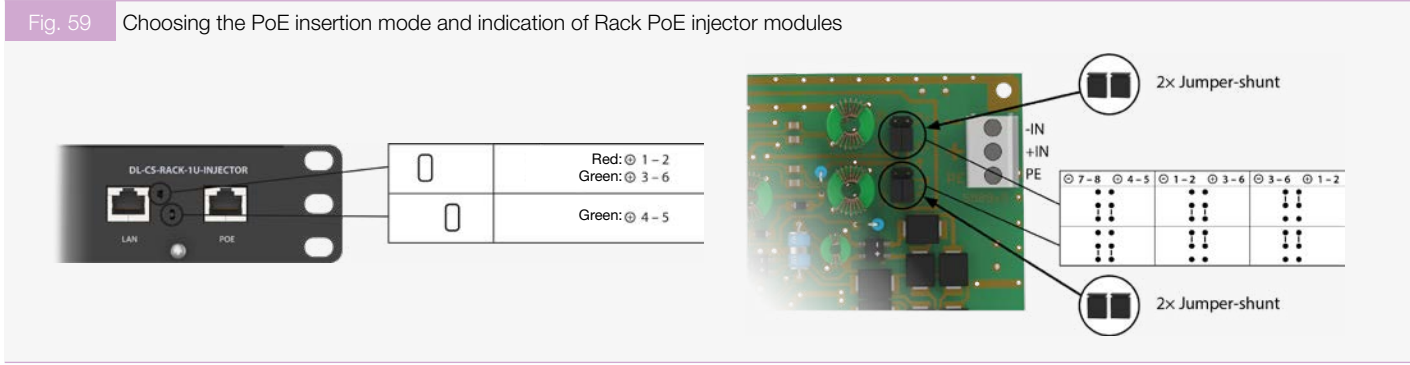

6. Examples of SPD applications – Antennas

6.1 Antenna Systems – Introduction

As regards the principle of functioning, antenna systems are devices that are, with a few exceptions, placed at sites exposed to atmospheric disturbances (storms). Therefore they automatically turn into devices that are at risk of thunderstorm activities and are exposed to adverse potentials arising from lightning, induction of nearby lightning strikes or from faults on medium voltage or high voltage power lines.

Antenna systems are electrically connected to a transmitter or receiver and these electronic devices are sensitive to various electromagnetic disturbances. Therefore, if we want to make these devices working reliably, it is necessary to ensure their maximum resistance to atmospheric disturbances and possibly disturbances arising at low and high voltage lines situated in the vicinity of antenna systems. From this it follows that it is necessary to secure these systems against lightning as well as against the induced voltage. This issue is addressed by a set of EN 62305 standards in accordance with the EN 60728-11 standard, ed. 2.

The EN 60728-11 standard ed. 2 shows in detail the basic principles of placing the antenna systems on building objects (buildings) and their protection against direct lightning strike, protection against induced surges, including the solution of bonding and grounding issues. The basic rule to protect antenna systems is their location which is to be situated in an area protected by LPS (the LPZ 0_B zone) while maintaining adequate distance “s”. This separation (isolation) distance “s”, which is between the antenna system and a trap (ATS – air terminal system) system or LPS (lightning rod) or any associated portions of the LPS, must meet or exceed values required by EN 62305-3. Antenna systems are not allowed to be

installed on buildings having a roof covered with easily flammable materials such as reed, thatch, bitumen board etc. Antenna down leads (coaxial cables, etc.) and grounding conductors must not be routed through areas where flammable materials such as oil, straw, hay and similar materials are stored, or through the spaces in which explosive gases may arise or accumulate (e.g. carpentry workshop).

6.2 Principle of protection of antenna network

The risk of atmospheric overvoltage entering via the antenna coaxial line of the antenna system mounted on a roof is a high danger for electrical installation in the building. In points of passing cables into a building (i.e. from LPZ 0_B to LPZ 1), a possible atmospheric overvoltage has to be prevented from penetrating into the building. In a point of entering the antenna cables into the building, the cables have to be grounded (their metal shielding). For grounding, a grounding kit can be used which is waterproof and weatherproof. Basic versions of the solution are shown in the following figures.

6.2.1 Protection of antenna system in space protected by lightning rod

If a building is equipped with the LPS system (lightning rod), which corresponds to EN 62305-3, it is necessary to install the antenna system in the protected area of the LPS (LPZ 0_B zone). This variant is in Fig. 61, where also bonding and grounding is being addressed, while observing a separation distance according to EN 62305-3.

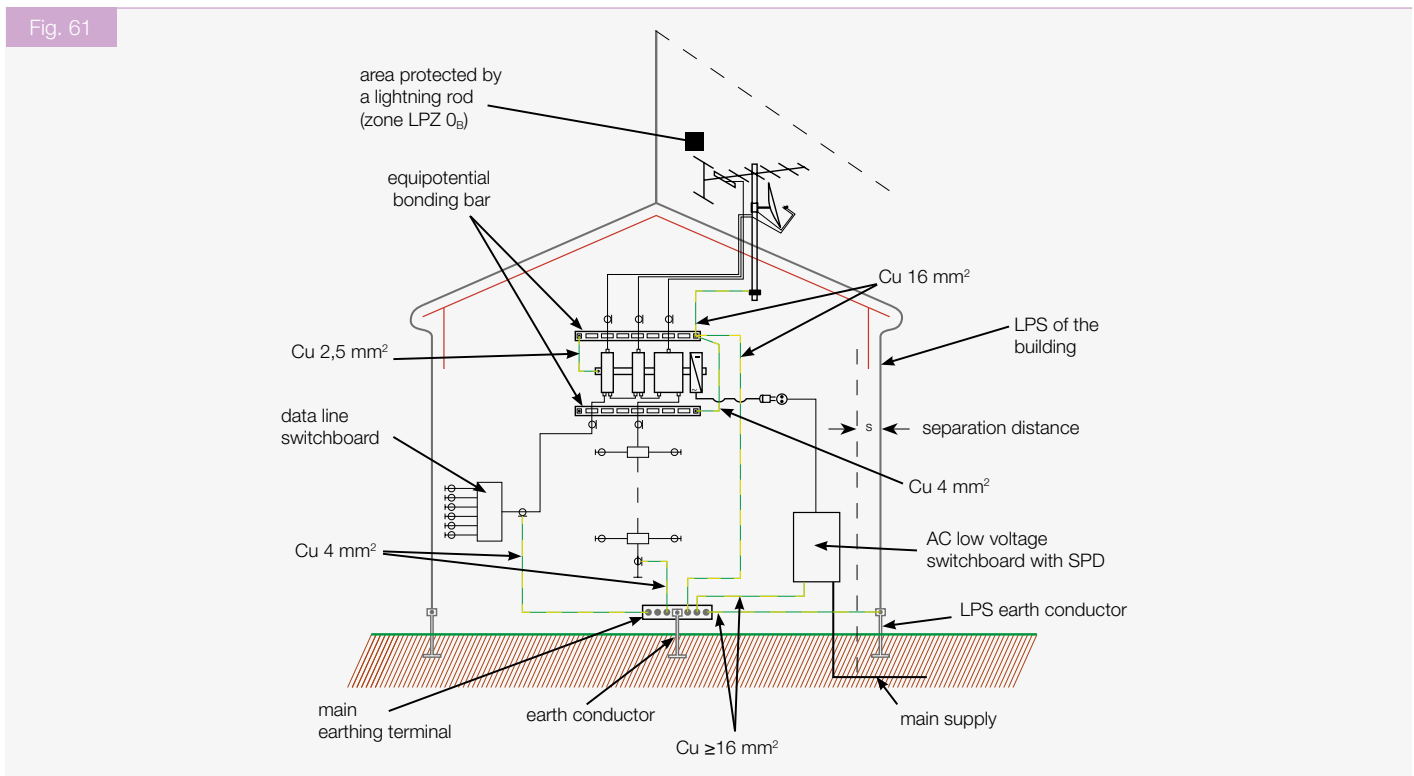

6.2.2. Protection of antenna system with distant lightning rod

In case the existing LPS does not allow to place the antenna system in a space protected by LPS (the LPZ 0_B zone) the situation can be resolved as per Fig. 62, where the existing LPS is completed with an ATS in a way for the antenna system to be situated in the LPZ 0_B zone.

6.2.3. Protection of antenna system non protected by lightning rod

If the antenna system is located outside of the LPZ 0_B zone, it means that it is now situated in an area no more protected by the LPS (LPZ 0_A zone). Mounting example of such antenna system is shown in Fig. 63. It can be seen that the ground conductors and bonding wires may not have a cross section less than 16 mm².

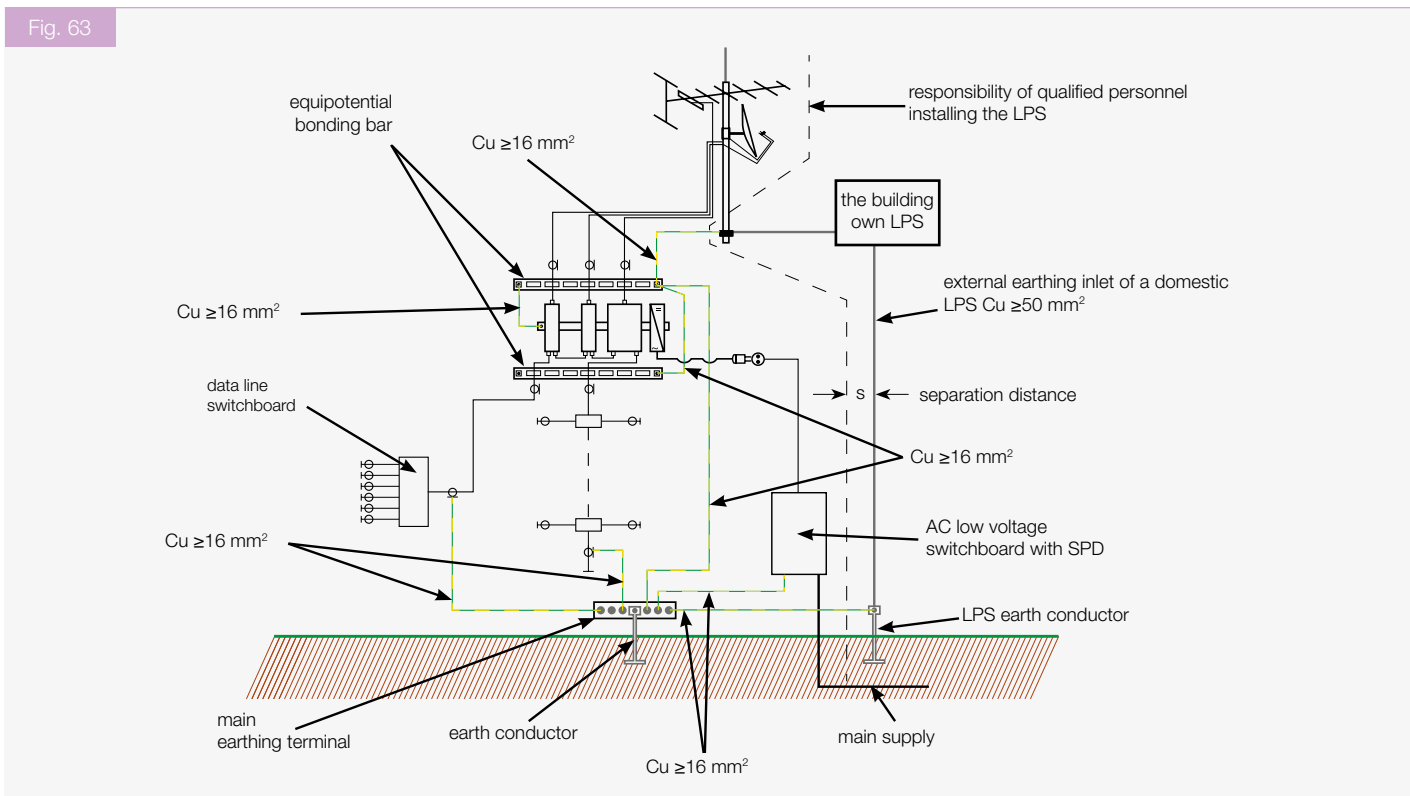
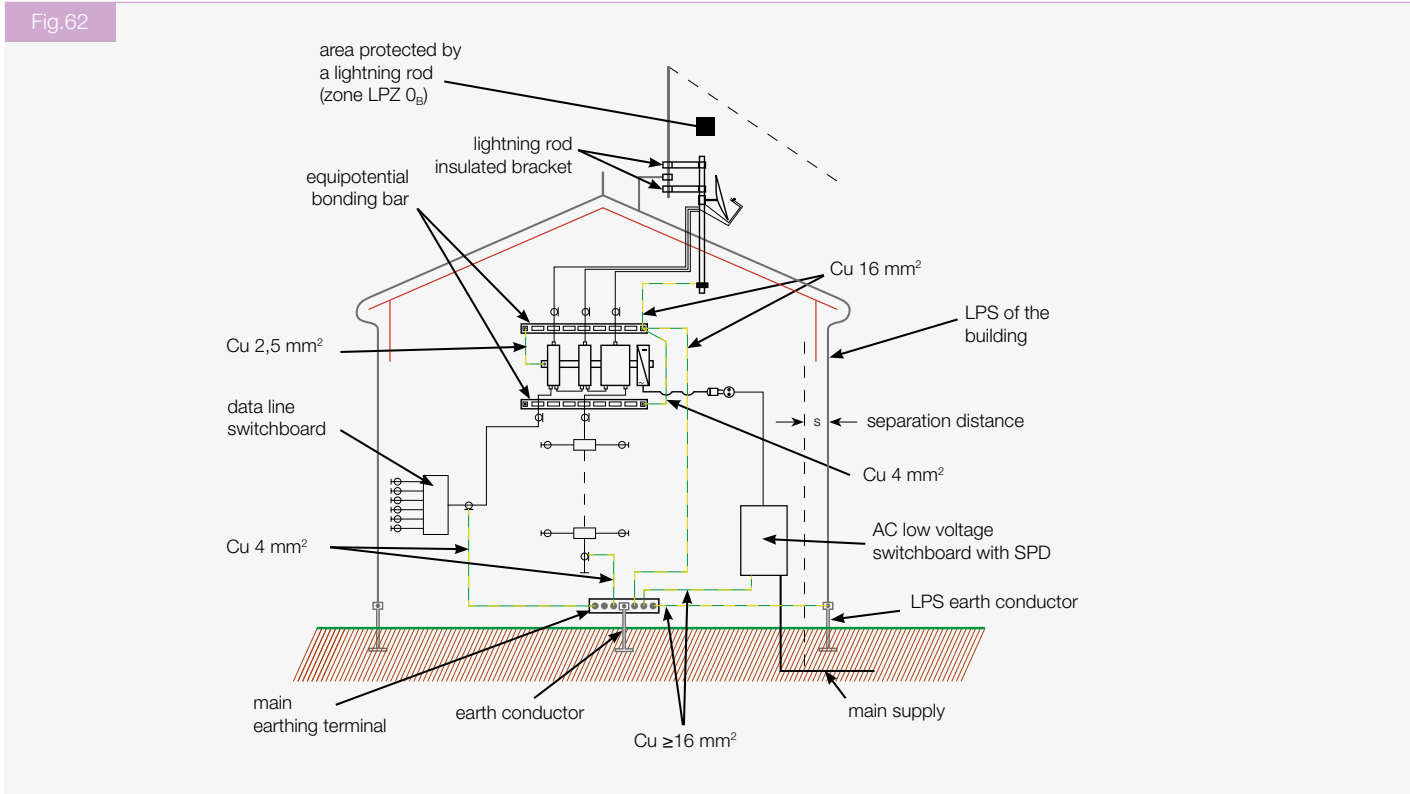

6.3. Protection of technology equipments in antenna RF signal distribution networks

Present-day technological equipment is threatened by electromagnetic fields originating from distant lightning strikes or disturbances at the MV and HV and is becoming more sensitive to unwelcome induced voltages induced on antenna systems and coaxial lines. At re-transmission points, system outputs, cable network stations or subscriber device inputs (e.g. at a satellite receiver, TV etc.), high voltages may appear which can destroy this technology. Protection of equipment from induced voltages is performed by equipotential bonding using surge protective devices (SPD) which provide for temporary equalization of potentials between the middle conductor and shielding (coaxial cable), or in IP-based systems (device connected to antenna via twisted pairs of UTP/STP cable) between wires of cable.

The coaxial SPDs range FX, SX, HX are used for the protection of a coaxial lines. In case of Wi-Fi antennas, SPDs enabling power supply via an STP cable are used for the protection e.g.,

DL-10G-PoE-IP66 or DL-10G-RJ45-POE-AB or DL-10G-RJ45-POE-AB), which are tested for lightning current.

Protection of the antenna system installed in the LPZ 0_B zone (see 6.2.1. and 6.2.2.) is shown in Figure 64.

Fig. 65 shows how the protection needs to be strengthened when the antenna is to be placed in the LPZ 0_A zone. For both of these systems to be effective, the SPD of type 3 needs to be installed both on the power and the signal sides.

Fig. 66 shows an example of protecting a WLAN receiver used for IPTV.

Fig. 67 shows a typical example of protecting an antenna distribution system in residential buildings up to a maximum height of 45 m, but for which it is necessary to fulfill conditions shown in the figure.

- 1 SPD (ST 1+2+3) - SX-090-F75 F/F with F connectors - it serves as a two-stage protection of the equipment at the cable entry to the LPZ 1 zone.

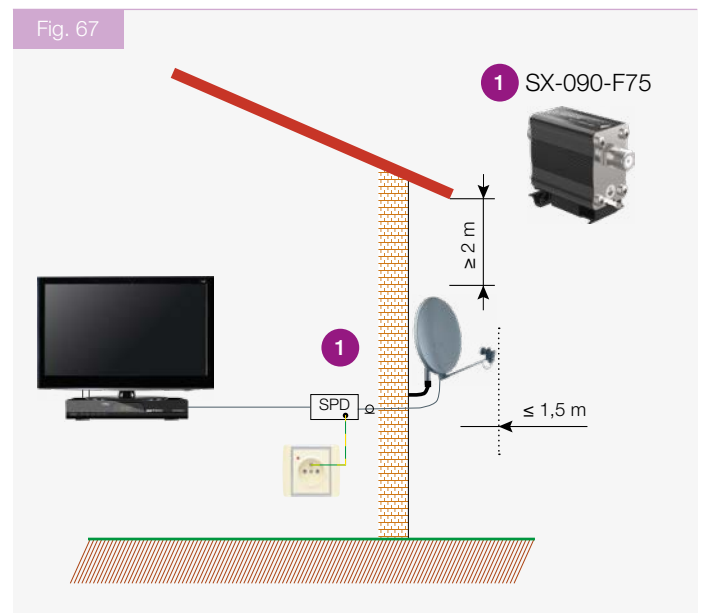
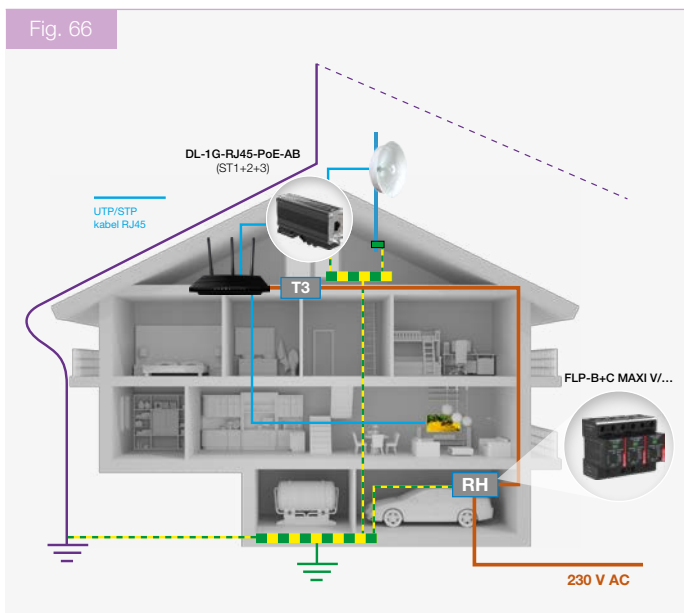
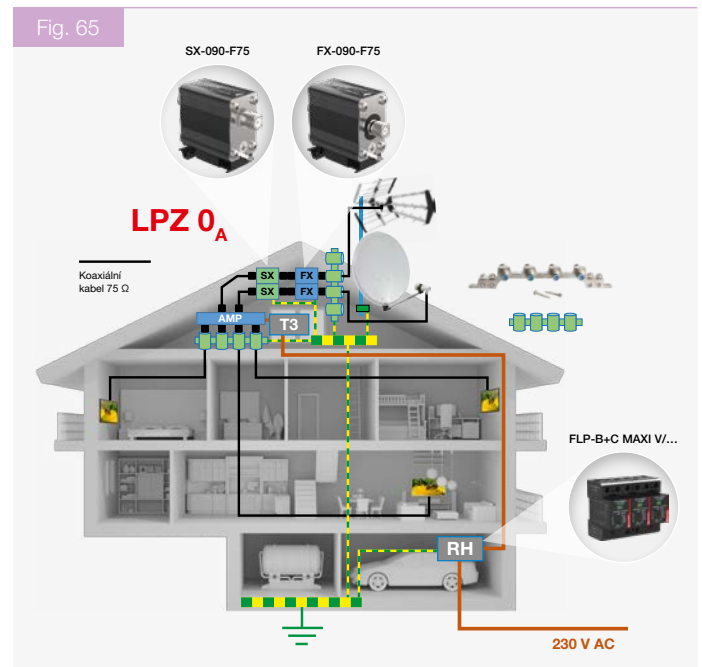
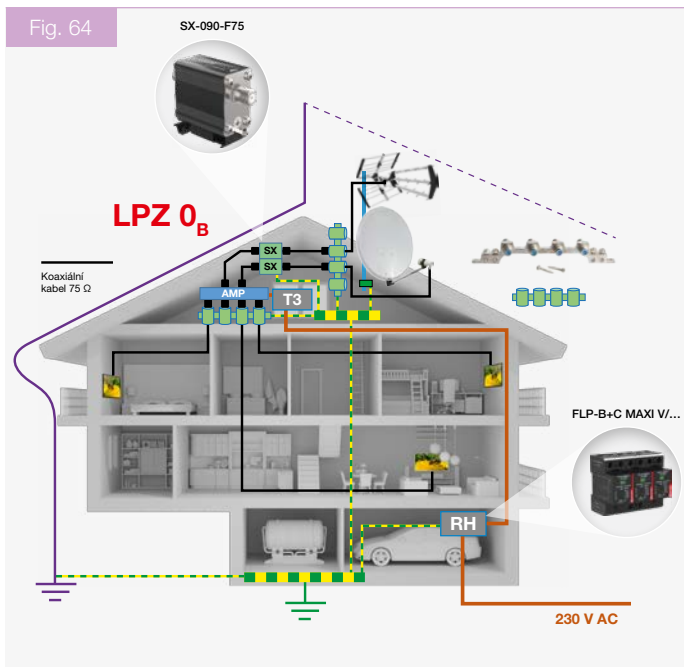

Notes

A large grid of graph paper for taking notes, consisting of 20 columns and 30 rows of small squares.

6.4 Protection of a large radiocommunication antenna system

Fig. 68 Protection of a large radiocommunication antenna system

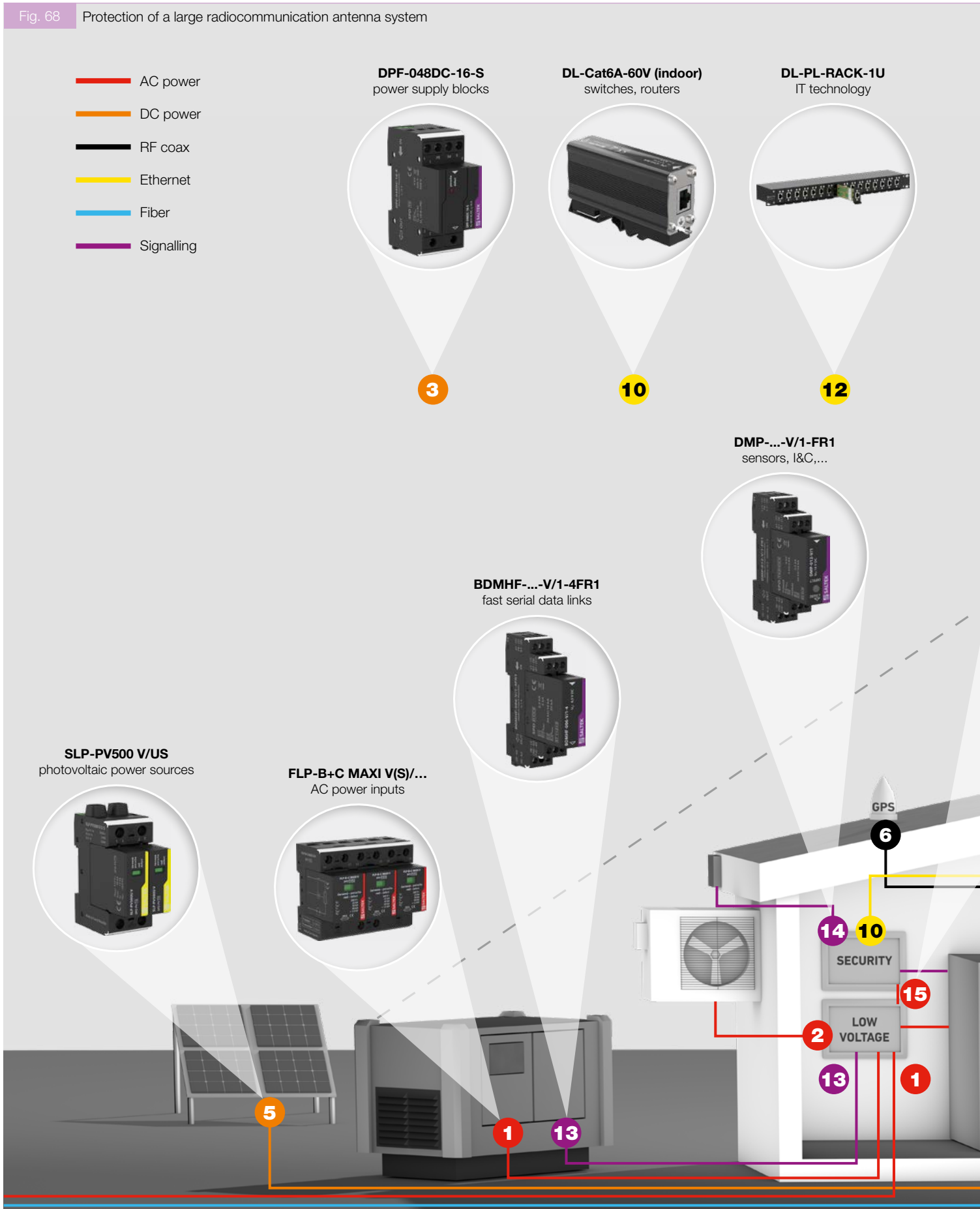

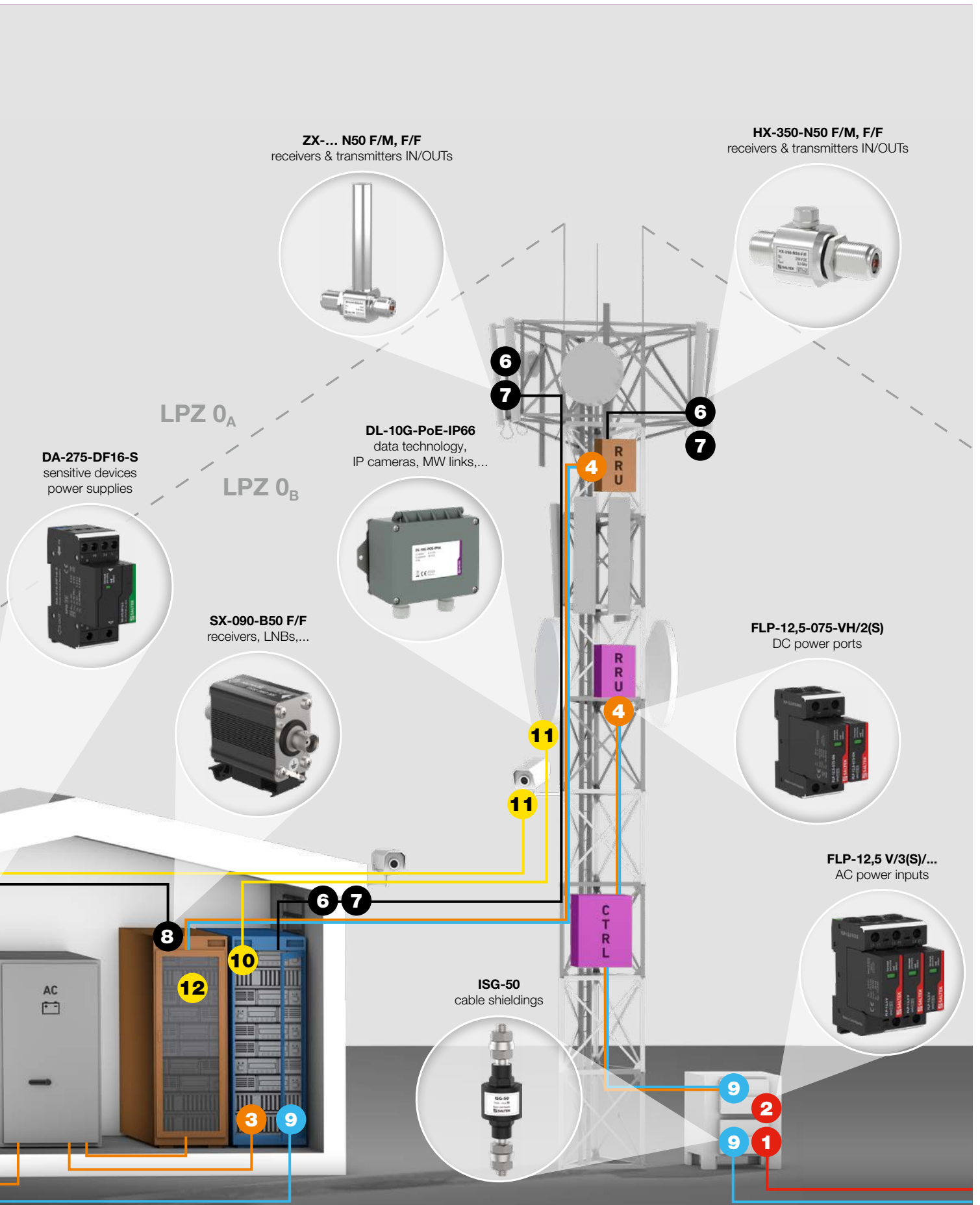

Products overview in Fig. 64, 65, 66, 67, 68



FX – lightning current arrester (coarse protection ST1) for coaxial lines with a frequency range of 0 to 2.15 GHz with the possibility of power supply via coaxial cable (BNC or F connectors). It is installed at the interface of LPZ 0 and LPZ 1 zones. Typical application for satellite or terrestrial reception.



SX – two-stage protection (ST 1+2+3) of TV (DVB-T2) and satellite (DVB-S2) receivers with the possibility of power supply via coaxial cable. Installation at the LPZ 0_B - LPZ 1 interface. Version with BNC 50 connector is designed for professional receivers.



HX – lightning arrester designed to protect coaxial inputs/outputs of telecommunication devices in the frequency band from 0 to 3.8 GHz, enabling powering via the cable.



ZX – Highly efficient tuned lightning arrester with I/4 technology designed to protect telecommunication equipment. It is intended to be used for telecommunication technologies with the ability to transmit a relatively narrow frequency band around the frequency to which it is tuned. It cannot be used with technologies that use coaxial lines for control or power supply voltage. This type of protection is in addition to surge (lightning) protection, and it prevents the generation of static electricity at the technology inputs.



VL – combined protection designed to protect analogue coaxial lines of CCTV camera systems.



DL-PL-RACK-1U + SPD modules – multichannel surge protection system for Ethernet with PoE and structured cabling (e.g. ISP applications, telecommunication towers, data centers, etc.).



DL-10G-PoE-IP66 – two-stage protection with IP66 rating for protection of Ethernet end devices with PoE located outdoors (microwave radios, IP cameras, information panels, etc.).



DL-1G-RJ45-POE-AB and DL-10G-RJ45-POE-AB – universal data protection, designed to be installed at the interfaces of LPZ 0_B and LPZ 1 zones. It allows data communication up to 1 Gbps, or the 10G version up to 10 Gbps. At the same time, it allows power supply over STP cable operated in the PoE mode.



Grounding kit – serves for additional grounding of external conductors (shielding) of coaxial lines.

7. Examples of SPD applications – Camera systems

7.1 Conditions for cameras placement

Closed camera systems have a wide variety of uses. These camera systems can be used in transport, surveillance systems, etc. and can be operated both indoors and outdoors. In the open space, these systems can be installed on the facade of objects, masts or portals.

On the market exist analog systems interconnected by coaxial cables or digital IP camera systems, which use FTP cabling for the transmission of data only, or data with powering.

The camera, which is installed on the facade of an object, must be located in a sufficient separation distance “s” from the LPS conductors system, i.e. the LPS system (see EN 62 305), eaves and all metallic parts connected to the earthing system. If this condition is met and the cable immediately passes through the enclosure wall inside the building (LPZ 0_B and LPZ 1), the effect of the lightning strike is negligible and only induced overvoltages should be considered. The SPDs ST 2+3 are used then (DL-Cat.6A-60V).

If the condition of a sufficient separation distance “s” is not met or a cable is installed on the facade of an object, the lightning strike problem has to be solved using lightning arresters. In this case, SPDs ST 1+2+3 have to be used (DL-10G-PoE-IP66 is the best).

The camera placed on a mast or a portal has to be installed in the protected angle area of the LPS system (LPZ 0_B). In this case, a lightning arrester has to be installed on the lines. For coaxial cables, the SX-090-F75 has to be used, and for IP cameras, the ST 1+2+3 protection has to be installed (DL-10G-PoE-IP66).

7.2 Protection of camera systems

7.2.1 Analog systems

The protection of analog systems those are interconnected by coaxial cables is assured by SPD range FX and VL. If the camera system is installed inside an the VL-B75 F/F devices should be used to protect quadrature encoder inputs and which should be grounded.

If the camera is located outside an object, the coaxial line should be equipped with the SPD type FX-090-B75 F/F, which is installed at the boundary of LPZ 0 and LPZ 1 zones.

If the camera is installed on the mast then the SPD type FX-090-B75T F/F should be used. The SPD should be connected to the same earthing point with the camera. If the camera is insulated, i.e. it is not connected to the ground at the installation site, then the overvoltage protection should be connected to the any other appropriate ground at the installation site, e.g. the metal grounded mast.

If the camera is not fixed but rotary, then the appropriate protection has to be installed on the control line as well. In case of cameras supplied by a small voltage and controlled via the RS-485 communication line, the combined SPD type DMP-xx-V/1-FR1 should be used (xx is the power supply voltage).

7.2.2 Digital IP camera systems

IP cameras transmit the signal via Ethernet line and that's why the same protective devices like for data lines should be used also here (see Chapter 5).

If the IP camera uses a data network installed inside a object to transmit a video signal only, then the SPD type DL-Cat.6A can be used. If the camera uses the data network also for powering, then the type DL-Cat.6A-60V plus has to be used. If the data network goes out the object, then the type DL-1G-RJ45-POE-AB has to be installed at the boundary LPZ 0-1. The same type of protection should be installed in front of the camera if protection of the camera is important for some reason, for example, to ensure a reliable operation. In terms of grounding, the same rules should be applied as for analog systems.

8. Examples of SPD applications – Telecommunications

8.1 Protection of telecommunication devices

8.1.1 Protection of power supply

To protect the device from the side of the low-voltage supply, we have to establish a complete so-called 3-stage protection (FLP = the 1st stage, SLP = the 2nd stage, DA = the 3rd stage). The third stage is recommended as a surge arrester installed in a socket outlet, in a box for a trunking systems, for an additional installation below the socket outlet or for a DIN rail (DA-275-DJ25). For PBX, and active elements of LAN and WAN networks, SPDs combined with a low-pass filter are recommended:

- DA-275-DF.. - for fixed lines
- PA-OVERDRIVE F16

8.1.2 Protection of telecommunication systems

Telecommunication lines pass from the outdoor to the building towards a switchboard (PBX) or a PC. These telecommunication lines are very long and are threatened by overvoltage caused by lightning strikes or by induction generated by various switching or disturbance phenomena. The basic principle of protection is in Fig. 69.

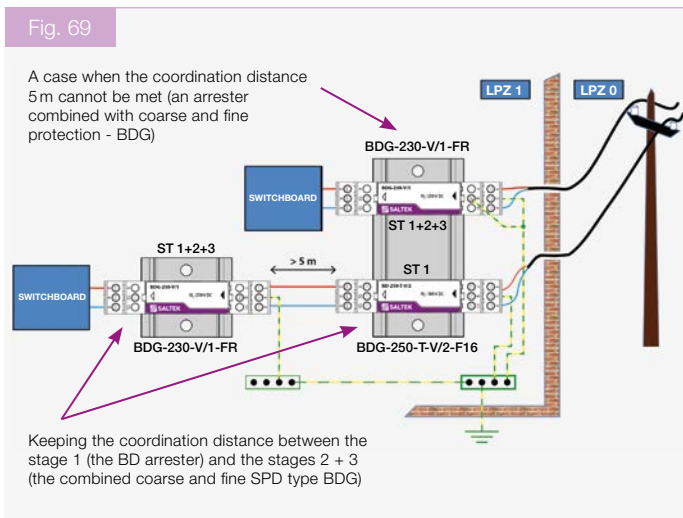

8.1.3 Protection of telecommunication signal distributions

An appropriate solution has to be optimized according to the number of lines and the kind of connection:

- for individual lines of the PBX type DL-TLF-UHF for analogue telephone and xDSL lines (ST 1+2+3);
- for PBXs, or the CLSA-TLF, CLSA-DSL to LSA PLUS types for mounting in disconnection rails (Krone rails);
- for ISDN distribution lines, the DL-ISDN RJ45 protectors with a cutoff frequency greater than 50 MHz or CLSA-ISDN for LSA PLUS (Krone) disconnection rails for transmission frequencies up to 16 MHz.

8.2 IP telephony

IP telephony is one of the ways how to use the Internet and make phone calls through it. IP telephony is voice transmission over data networks. Voice information is transmitted via communication networks based on the data transmission with the IP protocol. The same rules apply to the protection of communication lines as in the Internet data network.

8.2.1. Protection of IP telephony lines

The principle of protecting communication lines of IP telephony with ring signal is in Fig. 70. It is necessary to use SPD with higher level of U_p , e.g. DL-1G-RJ45-60V

In case of a conventional IP communication line, a standard Ethernet SPD (ST 2+3), the types DL-Cat.6A can be used. If the communication line goes out the building and passes the zone LPZ 0/1, the SPD (ST 1+2+3), the type DL-1G-RJ45-POE-AB should be used.

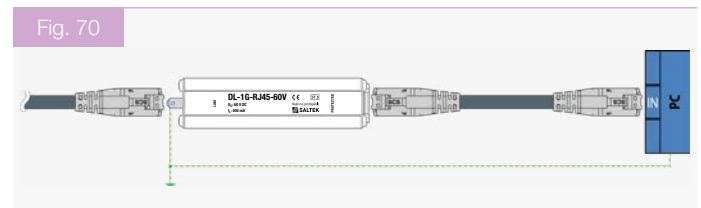

SPDs for data / signalling / telecommunication networks

Devices with pluggable module

BD-...-T-V/2-(F)16 range

Lightning current arrester. To protect two-core communication, data and other lines at the boundary of the LPZ 0 and LPZ 1 zones.



- Variants BD-250 for protection of telecommunication lines
- Installation at the line entry into building
- In "F" version is the line separated from protective earth via GDT

Type	Location	Number of lines	U _c	I _L	I _{imp} (D1)	I _n (C2)	U _p (C3)	Floating	Ordering number
BD-090-T-V/2-16	ST 1	2	70 V DC	16 A	2.5 kA	10 kA	550 V	No	A05550
BD-250-T-V/2-16	ST 1	2	180 V DC	16 A	2.5 kA	10 kA	550 V	No	A05551
BD-090-T-V/2-F16	ST 1	2	70 V DC	16 A	2.5 kA	10 kA	550 V	Yes	A05554
BD-250-T-V/2-F16	ST 1	2	180 V DC	16 A	2.5 kA	10 kA	550 V	Yes	A05555

BDM-...-V/...-FR... range

Lightning current arrester. It is specified for the protection of two-core communication, data and other lines and the communication interface of control I&C, electronic security and fire alarm systems, etc., at the boundary of the LPZ 0 and LPZ 1 zones or higher.



- Installation at the line entry into building, close to protected equipment
- Line separated from protective earth via GDT

Type	Location	Number of lines	U _c	I _L	I _{imp} (D1)	I _n (C2)	U _p (C3) core-core	Floating	Ordering number
BDM-006-V/1-FR1	ST 1+2+3	1	8.5 V DC	1 A	2.5 kA	10 kA	12 V	Yes	A05709
BDM-012-V/1-FR1	ST 1+2+3	1	16 V DC	1 A	2.5 kA	10 kA	22 V	Yes	A05710
BDM-024-V/1-FR1	ST 1+2+3	1	36 V DC	1 A	2.5 kA	10 kA	46 V	Yes	A05711
BDM-048-V/1-FR1	ST 1+2+3	1	51 V DC	1 A	2.5 kA	10 kA	65 V	Yes	A05712
BDM-060-V/1-FR1	ST 1+2+3	1	64 V DC	1 A	2.5 kA	10 kA	85 V	Yes	A06438
BDM-230-V/1-FR1	ST 1+2+3	1	250 V DC	1 A	2.5 kA	10 kA	350 V	Yes	A06461
BDM-230-V/1-FR	ST 1+2+3	1	250 V DC	0.5 A	2.5 kA	10 kA	350 V	Yes	A05713
BDM-006-V/1-FR2	ST 1+2+3	1	8.5 V DC	2 A	2.5 kA	10 kA	12 V	Yes	A06385
BDM-012-V/1-FR2	ST 1+2+3	1	16 V DC	2 A	2.5 kA	10 kA	22 V	Yes	A06398
BDM-024-V/1-FR2	ST 1+2+3	1	36 V DC	2 A	2.5 kA	10 kA	46 V	Yes	A06411
BDM-048-V/1-FR2	ST 1+2+3	1	51 V DC	2 A	2.5 kA	10 kA	65 V	Yes	A06424
BDM-060-V/1-FR2	ST 1+2+3	1	64 V DC	2 A	2.5 kA	10 kA	85 V	Yes	A06439
BDM-006-V/2-FR1	ST 1+2+3	2	8.5 V DC	1 A	2.5 kA	10 kA	12 V	Yes	A06388
BDM-012-V/2-FR1	ST 1+2+3	2	16 V DC	1 A	2.5 kA	10 kA	22 V	Yes	A06401
BDM-024-V/2-FR1	ST 1+2+3	2	36 V DC	1 A	2.5 kA	10 kA	46 V	Yes	A06414
BDM-048-V/2-FR1	ST 1+2+3	2	51 V DC	1 A	2.5 kA	10 kA	65 V	Yes	A06427
BDM-060-V/2-FR1	ST 1+2+3	2	64 V DC	1 A	2.5 kA	10 kA	85 V	Yes	A06443
BDM-230-V/2-FR	ST 1+2+3	2	250 V DC	0.5 A	2.5 kA	10 kA	350 V	Yes	A06464

SPDs for data / signalling / telecommunication networks

Devices with pluggable module

BDM-...-V/...-JFR... range

Lightning current arrester with coarse and fine protection. It is specified for the protection of single-core lines of communication, data and other lines with common neutral and protective earth against surge voltage. Suitable for potential free contacts of the communication interface in I&C, electronic security and fire alarm systems, etc., at the boundary of the LPZ 0 and LPZ 1 zones or higher.



- Installation at the line entry into building, close to protected equipment
- Line separated from protective earth via GDT

Type	Location	Number of lines	U _c	I _L	I _{imp} (D1)	I _n (C2)	U _p (C3) core-core/GND	Floating	Ordering number
BDM-006-V/2-JFR1	ST 1+2+3	2	8.5 V DC	1 A	2.5 kA	10 kA	12 V	Yes	A06390
BDM-006-V/2-JFR2	ST 1+2+3	2	8.5 V DC	2 A	2.5 kA	10 kA	12 V	Yes	A06391
BDM-012-V/2-JFR1	ST 1+2+3	2	16 V DC	1 A	2.5 kA	10 kA	22 V	Yes	A06403
BDM-012-V/2-JFR2	ST 1+2+3	2	16 V DC	2 A	2.5 kA	10 kA	22 V	Yes	A06404
BDM-024-V/2-JFR1	ST 1+2+3	2	36 V DC	1 A	2.5 kA	10 kA	46 V	Yes	A06416
BDM-024-V/2-JFR2	ST 1+2+3	2	36 V DC	2 A	2.5 kA	10 kA	46 V	Yes	A06417
BDM-048-V/2-JFR1	ST 1+2+3	2	51 V DC	1 A	2.5 kA	10 kA	65 V	Yes	A06429
BDM-048-V/2-JFR2	ST 1+2+3	2	51 V DC	2 A	2.5 kA	10 kA	65 V	Yes	A06430
BDM-006-V/4-JFR1	ST 1+2+3	4	8.5 V DC	1 A	2.5 kA	10 kA	12 V	Yes	A06396
BDM-012-V/4-JFR1	ST 1+2+3	4	16 V DC	1 A	2.5 kA	10 kA	22 V	Yes	A06409
BDM-024-V/4-JFR1	ST 1+2+3	4	36 V DC	1 A	2.5 kA	10 kA	46 V	Yes	A06422
BDM-048-V/4-JFR1	ST 1+2+3	4	51 V DC	1 A	2.5 kA	10 kA	65 V	Yes	A06435

BDMHF-...-V/1-FR1 range

Lightning current arrester with coarse and fine protection for industrial interfaces. For the protection of high-speed two-/four-core signal lines against surge voltage. Suitable for the communication interface of I&C, electronic security and fire alarm systems, etc., RS485 and PROFIBUS mainly.



- Suitable for high-speed signalling lines
- Installation at the line entry into building, close to protected equipment
- Line separated from protective earth via GDT

Type	Location	Number of lines	U _c	I _L	I _{imp} (D1)	I _n (C2)	U _p (C3) core-core/GND	Floating	Ordering number
BDMHF-006-V/1-FR1	ST 1+2+3	1	8.5 V DC	1 A	2.5 kA	10 kA	14 V	Yes	A06547
BDMHF-024-V/1-FR1	ST 1+2+3	1	36 V DC	1 A	2.5 kA	10 kA	48 V	Yes	A06553
BDMHF-006-V/1-4FR1	ST 1+2+3	1 four-core	8.5 V DC	1 A	2.5 kA	10 kA	16 V	Yes	A06545
BDMHF-024-V/1-4FR1	ST 1+2+3	1 four-core	36 V DC	1 A	2.5 kA	10 kA	48 V	Yes	A06551

SPDs for data / signalling / telecommunication networks

Devices with pluggable module

BDG-...-V/...-FR... range

Lightning current arrester with coarse and fine protection. For the protection of up to four-core lines of communication, data and other lines against surge voltage. Suitable for the telecommunication lines and communication interface of I&C, electronic security and fire alarm systems, etc., RS485, RS422 and RS232 mainly.



- Installation at the line entry into building, close to protected equipment
- Line separated from protective earth via GDT

Type	Location	Number of liNos	U _c	I _L	I _{imp} (D1)	I _n (C2)	U _p (C3) core-core	Floating	Ordering number
BDG-006-V/1-FR1	ST 1+2+3	1	8.5 V DC	1 A	2.5 kA	10 kA	12 V	Yes	A05704
BDG-012-V/1-FR1	ST 1+2+3	1	16 V DC	1 A	2.5 kA	10 kA	22 V	Yes	A05705
BDG-024-V/1-FR1	ST 1+2+3	1	36 V DC	1 A	2.5 kA	10 kA	46 V	Yes	A05706
BDG-048-V/1-FR1	ST 1+2+3	1	51 V DC	1 A	2.5 kA	10 kA	65 V	Yes	A05707
BDG-060-V/1-FR1	ST 1+2+3	1	64 V DC	1 A	2.5 kA	10 kA	85 V	Yes	A06499
BDG-230-V/1-FR1	ST 1+2+3	1	250 V DC	1 A	2.5 kA	10 kA	350 V	Yes	A06514
BDG-230-V/1-FR	ST 1+2+3	1	250 V DC	0.5 A	2.5 kA	10 kA	350 V	Yes	A05708
BDG-006-V/1-FR2	ST 1+2+3	1	8.5 V DC	2 A	2.5 kA	10 kA	12 V	Yes	A06469
BDG-012-V/1-FR2	ST 1+2+3	1	16 V DC	2 A	2.5 kA	10 kA	22 V	Yes	A06477
BDG-024-V/1-FR2	ST 1+2+3	1	36 V DC	2 A	2.5 kA	10 kA	46 V	Yes	A06485
BDG-048-V/1-FR2	ST 1+2+3	1	51 V DC	2 A	2.5 kA	10 kA	65 V	Yes	A06493
BDG-060-V/1-FR2	ST 1+2+3	1	64 V DC	2 A	2.5 kA	10 kA	85 V	Yes	A06500
BDG-006-V/2-FR1	ST 1+2+3	2	8.5 V DC	1 A	2.5 kA	10 kA	12 V	Yes	A06472
BDG-012-V/2-FR1	ST 1+2+3	2	16 V DC	1 A	2.5 kA	10 kA	22 V	Yes	A06480
BDG-024-V/2-FR1	ST 1+2+3	2	36 V DC	1 A	2.5 kA	10 kA	46 V	Yes	A06488
BDG-048-V/2-FR1	ST 1+2+3	2	51 V DC	1 A	2.5 kA	10 kA	65 V	Yes	A06496
BDG-060-V/2-FR1	ST 1+2+3	2	64 V DC	1 A	2.5 kA	10 kA	85 V	Yes	A06504
BDG-230-V/2-FR	ST 1+2+3	2	250 V DC	0.5 A	2.5 kA	10 kA	350 V	Yes	A06517
BDG-006-V/1-4FR1	ST 1+2+3	4 (2x2)	8.5 V DC	1 A	2.5 kA	10 kA	18 V	Yes	A06467
BDG-012-V/1-4FR1	ST 1+2+3	4 (2x2)	16 V DC	1 A	2.5 kA	10 kA	24 V	Yes	A06475
BDG-024-V/1-4FR1	ST 1+2+3	4 (2x2)	36 V DC	1 A	2.5 kA	10 kA	46 V	Yes	A06483
BDG-048-V/1-4FR1	ST 1+2+3	4 (2x2)	51 V DC	1 A	2.5 kA	10 kA	90 V	Yes	A06491

BDGHF-...-V/...-FR... range

Lightning current arrester with coarse and fine protection for industrial interfaces. For the protection of high-speed two-core signal lines against surge voltage. Suitable for the telecommunication lines and communication interface of I&C, electronic security and fire alarm systems, etc., RS485 and PROFIBUS mainly.



- Suitable for high-speed signalling lines
- Installation at the line entry into building, close to protected equipment
- Line separated from protective earth via GDT

Type	Location	Number of lines	U _c	I _L	I _{imp} (D1)	I _n (C2)	U _p (C3) core-core	Floating	Ordering number
BDGHF-006-V/1-FR1	ST 1+2+3	1	8.5 V DC	1 A	2.5 kA	10 kA	14 V	Yes	A06520
BDGHF-012-V/1-FR1	ST 1+2+3	1	16 V DC	1 A	2.5 kA	10 kA	24 V	Yes	A06526
BDGHF-024-V/1-FR1	ST 1+2+3	1	36 V DC	1 A	2.5 kA	10 kA	48 V	Yes	A06532
BDGHF-230-V/1-FR	ST 1+2+3	1	250 V DC	0.5 A	2.5 kA	10 kA	350 V	Yes	A06538
BDGHF-006-V/2-FR1	ST 1+2+3	2	8.5 V DC	1 A	2.5 kA	10 kA	14 V	Yes	A06523
BDGHF-012-V/2-FR1	ST 1+2+3	2	16 V DC	1 A	2.5 kA	10 kA	24 V	Yes	A06529
BDGHF-024-V/2-FR1	ST 1+2+3	2	36 V DC	1 A	2.5 kA	10 kA	48 V	Yes	A06535
BDGHF-230-V/2-FR	ST 1+2+3	2	250 V DC	0.5 A	2.5 kA	10 kA	350 V	Yes	A06541

SPDs for data / signalling / telecommunication networks

Devices with pluggable module

DMP-...-V/1-...FR1 range

Combined coarse and fine protection in data part and surge protection for ELV in power supply part. For protection of the communication interfaces of I&C, electronic security and fire alarm systems, etc., mainly for measuring circuits and sensors, where signal and power supply are transmitted in one cable, against surge voltage.



- For circuits where signal and power supply are transmitted in one cable
- Installation close to protected equipment
- Visual fault signalling
- Line separated from protective earth via GDT

Type	Location	Number of lines	U _c	I _L	I _n (C2)	U _p (C3) core-core/GND	Floating	Ordering number
DMP-012-V/1-FR1	ST 2+3	1 two-core	16 V DC	1 A	10 kA	22 V	Yes	A05798
DMP-024-V/1-FR1	ST 2+3	1 two-core	36 V DC	1 A	10 kA	46 V	Yes	A05799
DMP-012-V/1-JFR1	ST 2+3	1 single-core	16 V DC	1 A	10 kA	–	Yes	A05802
DMP-024-V/1-JFR1	ST 2+3	1 single-core	36 V DC	1 A	10 kA	–	Yes	A05803

DP-...-V/1-F16 range

Universal surge protection specified for the protection of direct or alternating low voltage distribution against surge voltage.



- Installation close to protected equipment
- Visual fault signalling

Type	Location	Number of lines	U _c	I _L	I _n (C2)	U _p (C3) core-PE	Floating	Ordering number
DP-012-V/1-F16	ST 2	1	20 V AC/DC	16 A	2 kA	750 V	Yes	A05664
DP-024-V/1-F16	ST 2	1	34 V AC/DC	16 A	2 kA	750 V	Yes	A05665
DP-048-V/1-F16	ST 2	1	60 V AC/DC	16 A	2 kA	750 V	Yes	A05666

DMG-024-V/1-4FR1-DIF

Coarse and fine surge protection only in differential mode (core – core) for protection of up to four-cores lines of communication, data and other lines against surge voltage where SPD cannot be connected to bonding or earthing system.



Type	Location	Number of lines	U _c	I _L	I _n (C2)	U _p (C3) core-PE	Floating	Ordering number
DMG-024-V/1-4FR1-DIF	ST 2+3	1 four-core	24 V DC	1 A	10 kA	46 V	Yes	A06281

SPDs for data / signalling / telecommunication networks

Compact devices

BD-...-T range

Lightning current arrester. To protect two-core communication, data and other lines at the boundary of the LPZ 0 and LPZ 1 zones, against surge voltage.



- Variant BD-250 for protection of telecommunication lines
- Installation at the line entry into building
- Coarse protection between lines and protective earth

Type	Location	Number of lines	U _c	I _L	I _{imp} (D1) per core	I _n (C2) per core	U _p (C3) core-PE	Floating	Ordering number
BD-090-T	ST 1	1	70 V DC	1.6 A	2.5 kA	10 kA	550 V	Yes	A05821
BD-250-T	ST 1	1	180 V DC	1.6 A	2.5 kA	10 kA	550 V	Yes	A05822

DM-.../1 ... DJ range

Combined coarse and fine protection. For the protection of up to four-core communication, data and other lines with common earth, against surge voltage. Suitable for the communication interface of I&C, electronic security and fire alarm systems.



- Installation close to protected equipment
- Variants with resistive (R) or inductive (L) coupling impedance
- In 3/4 version, the line section is separated from the ground by a lightning arrester (floating)

Type	Location	Number of lines	U _c	I _L	I _n (C2)	U _p (C3) core-PE	Floating	Ordering number
DM-006/1-R-DJ	ST 2+3	1	8.1 V DC	0.06 A	10 kA	20 V	No	A06726
DM-012/1-R-DJ	ST 2+3	1	14.5 V DC	0.06 A	10 kA	35 V	No	A06727
DM-024/1-R-DJ	ST 2+3	1	29.1 V DC	0.06 A	10 kA	50 V	No	A06728
DM-048/1-R-DJ	ST 2+3	1	50.2 V DC	0.06 A	10 kA	80 V	No	A06729
DM-012/1-L2-DJ	ST 2+3	1	14.5 V DC	2 A	10 kA	35 V	No	A06731
DM-024/1-L2-DJ	ST 2+3	1	29.1 V DC	2 A	10 kA	50 V	No	A06732
DM-048/1-L2-DJ	ST 2+3	1	50.2 V DC	2 A	10 kA	80 V	No	A06733
DM-006/1 3R DJ	ST 2+3	1 three-core	8.1 V DC	0.06 A	10 kA	350 V	Yes	A01350
DM-012/1 3R DJ	ST 2+3	1 three-core	14.5 V DC	0.06 A	10 kA	350 V	Yes	A01349
DM-024/1 3R DJ	ST 2+3	1 three-core	29.1 V DC	0.06 A	10 kA	350 V	Yes	A01234
DM-006/1 3L DJ	ST 2+3	1 three-core	8.1 V DC	0.37 A	10 kA	350 V	Yes	A01402
DM-012/1 3L DJ	ST 2+3	1 three-core	14.5 V DC	0.37 A	10 kA	350 V	Yes	A02094
DM-024/1 3L DJ	ST 2+3	1 three-core	29.1 V DC	0.37 A	10 kA	350 V	Yes	A01519
DM-006/1 4R DJ	ST 2+3	1 four-core	8.1 V DC	0.06 A	10 kA	350 V	Yes	A01675
DM-012/1 4R DJ	ST 2+3	1 four-core	14.5 V DC	0.06 A	10 kA	350 V	Yes	A01689
DM-024/1 4R DJ	ST 2+3	1 four-core	29.1 V DC	0.06 A	10 kA	350 V	Yes	A01357

SPDs for data / signalling / telecommunication networks

Compact devices

DMS-... range

Special coarse and fine surge protection with resistance to incoming AC voltage and current limiting. For protection of communication interface, mainly the measuring loops of I&C, electronic security and fire alarm systems, etc., against transient overvoltage where are long parallel lines with power network.



- Installation close to protected equipment
- Line separated from protective earth via GDT

Type	Location	Number of lines	U_c	I_L	I_n (C2)	U_p (C3) core-PE	Floating	Ordering number
DMS-024-T	ST 2+3	1	33 V DC	0.06 A	5 kA	500 V	Yes	A06596
DMS-048-T	ST 2+3	1	56 V DC	0.06 A	5 kA	500 V	Yes	A06597

DP...-... range

Universal surge protection specified for the protection of direct or alternating low voltage distribution against surge voltage.



- Variant DPF-... with integrated RFI filter
- Installation close to protected equipment
- Visual fault signalling

Type	Location	RFI filter	U_c	I_L	I_n (C2)	U_p (C3) core-PE	Fault signalling	Ordering number
DP-012-25	ST 2	Ne	20 V AC/DC	25 A	8 kV	550 V	Visual	A06096
DP-024-25	ST 2	Ne	34 V AC/DC	25 A	8 kV	550 V	Visual	A06097
DP-048-25	ST 2	Ne	60 V AC/DC	25 A	8 kV	550 V	Visual	A06098
DPF-012DC-16	ST 2	Ano	20 V AC/DC	16 A	8 kV	500 V	Visual	A06635
DPF-012DC-16-S	ST 2	Ano	20 V AC/DC	16 A	8 kV	500 V	Visual, remote	A06664
DPF-024DC-16	ST 2	Ano	34 V AC/DC	16 A	8 kV	500 V	Visual	A06636
DPF-024DC-16-S	ST 2	Ano	34 V AC/DC	16 A	8 kV	500 V	Visual, remote	A06665
DPF-048DC-16	ST 2	Ano	60 V AC/DC	16 A	8 kV	500 V	Visual	A06637
DPF-048DC-16-S	ST 2	Ano	60 V AC/DC	16 A	8 kV	500 V	Visual, remote	A06666

SPDs for data / signalling / telecommunication networks

Terminal blocks with screw terminals

DM, DMG, DMJ, DMHF, DMLF, DS range

Surge protections for single- and two-core lines. Suitable for protection of telecommunication, measuring, signal lines and communication interfaces of I&C, electronic security and fire alarm systems, etc. against effects of surge voltage. Installation close to protected equipment.



- Multiple core lines significantly save the space
- Screw terminals
- Side cover in the scope of delivery for each piece

Type	Location	U_c	I_L	I_n (C2) (8/20 μ s)	U_p (C3) core-core	U_p (C3) core-PE	Threshold frequency	Ordering number
DM-006/1-RS	ST 2+3	8.5 V DC	0.5 A	5 kA	12 V	15 V	1 MHz	A05140
DM-012/1-RS	ST 2+3	16 V DC	0.5 A	5 kA	20 V	20 V	2 MHz	A05141
DM-024/1-RS	ST 2+3	36 V DC	0.5 A	5 kA	45 V	45 V	4 MHz	A05142
DM-048/1-RS	ST 2+3	51 V DC	0.5 A	5 kA	65 V	65 V	5 MHz	A05143
DM-060/1-RS	ST 2+3	64 V DC	0.5 A	5 kA	85 V	85 V	6.5 MHz	A05129
DMG-006/1-RS	ST 2+3	8.5 V DC	0.5 A	5 kA	12 V	500 V	1 MHz	A05132
DMG-012/1-RS	ST 2+3	16 V DC	0.5 A	5 kA	20 V	500 V	2 MHz	A05133
DMG-024/1-RS	ST 2+3	36 V DC	0.5 A	5 kA	45 V	500 V	4 MHz	A05134
DMG-048/1-RS	ST 2+3	51 V DC	0.5 A	5 kA	65 V	500 V	5 MHz	A05135
DMG-060/1-RS	ST 2+3	64 V DC	0.5 A	5 kA	85 V	500 V	6.5 MHz	A05136
DMJ-012/2-RS	ST 2+3	16 V DC	0.5 A	5 kA	-	20 V	2 MHz	A05144
DMJ-024/2-RS	ST 2+3	36 V DC	0.5 A	5 kA	-	45 V	4 MHz	A05145
DMJ-048/2-RS	ST 2+3	51 V DC	0.5 A	5 kA	-	65 V	5 MHz	A05131
DMJ-060/2-RS	ST 2+3	64 V DC	0.5 A	5 kA	-	85 V	6.5 MHz	A05146
DMHF-006/1-RS	ST 2+3	8.5 V DC	0.5 A	5 kA	14 V	500 V	70 MHz	A05138
DMHF-015/1-RS	ST 2+3	22 V DC	0.5 A	5 kA	28 V	500 V	70 MHz	A05139
DMLF-024/1-RS	ST 2	31 V DC	0.1 A	5 kA	55 V	55 V	0.07 MHz	A05333
DS-B090-RS	ST 2	70 V DC	16 A	10 kA	-	550 V	-	A05148
DS-B240-RS	ST 2	180 V DC	16 A	10 kA	-	600 V	-	A05149
DS-D024-RS	ST 3	29.1 V DC	16 A	0.3 kA	-	-	-	A05153
DS-V130-RS	ST 2	180 V DC	16 A	6 kA	-	-	-	A05151

SPDs for data / signalling / telecommunication networks

Terminal blocks with screwless terminals

DM, DMG, DMJ, DMHF, DMLF, DS range

Surge protections for single- and two-core lines. Suitable for protection of telecommunication, measuring, signal lines and communication interfaces of I&C, electronic security and fire alarm systems, etc. against effects of surge voltage. Installation close to protected equipment.



- Multiple core lines significantly save the space
- Screwless terminals for easy connection
- Side cover in the scope of delivery for each piece

Type	Location	U _c	I _L	I _n (C2) (8/20 μs)	U _p (C3) core-core	U _p (C3) core-PE	Threshold frequency	Ordering number
DM-006/1-RB	ST 2+3	8.5 V DC	0.5 A	5 kA	12 V	15 V	1 MHz	A06057
DM-012/1-RB	ST 2+3	16 V DC	0.5 A	5 kA	20 V	20 V	2 MHz	A06058
DM-024/1-RB	ST 2+3	36 V DC	0.5 A	5 kA	45 V	45 V	4 MHz	A06059
DM-048/1-RB	ST 2+3	51 V DC	0.5 A	5 kA	65 V	65 V	5 MHz	A06060
DMG-006/1-RB	ST 2+3	8.5 V DC	0.5 A	5 kA	12 V	500 V	1 MHz	A06061
DMG-024/1-RB	ST 2+3	36 V DC	0.5 A	5 kA	45 V	500 V	4 MHz	A06062
DMG-048/1-RB	ST 2+3	51 V DC	0.5 A	5 kA	65 V	500 V	5 MHz	A06063
DMJ-012/2-RB	ST 2+3	16 V DC	0.5 A	5 kA	-	20 V	2 MHz	A06065
DMJ-024/2-RB	ST 2+3	36 V DC	0.5 A	5 kA	-	45 V	4 MHz	A06066
DMJ-048/2-RB	ST 2+3	51 V DC	0.5 A	5 kA	-	65 V	5 MHz	A06067
DMHF-006/1-RB	ST 2+3	8.5 V DC	0.5 A	5 kA	14 V	500 V	70 MHz	A06064
DMHF-015/1-RB	ST 2+3	22 V DC	0.5 A	5 kA	28 V	500 V	70 MHz	A06290
DMLF-024/1-RB	ST 2	31 V DC	0.1 A	5 kA	55 V	55 V	0.07 MHz	A06069
DS-B090-RB	ST 2	70 V DC	10 A	10 kA	-	550 V	-	A06070

For LSA-PLUS strips

CLSA-... range

Combination of coarse and fine protection of data, I&C and telecommunication lines against effects of surge voltage.



- For LSA-PLUS separating strips
- Accessories: comb earthing rail

Type	Location	U _c	I _L	I _n (C2) (8/20 μs)	U _p (C3) core-core	U _p (C3) core-PE	Threshold frequency	Ordering number
CLSA-24	ST 2+3	36 V DC	0.5 A	5 kA	48 V	350 V	4 MHz	A05171
CLSA-48	ST 2+3	51 V DC	0.5 A	5 kA	65 V	350 V	6.5 MHz	A05172
CLSA-DSL	ST 2+3	170 V DC	0.5 A	5 kA	230 V	400 V	65 MHz	A05176
CLSA-TLF	ST 2+3	170 V DC	0.5 A	5 kA	230 V	350 V	14 MHz	A05173
CLSA-ISDN	ST 2+3	120 V DC	0.5 A	5 kA	170 V	350 V	16 MHz	A05174

SPDs for data / signalling / telecommunication networks

SPDs for Ethernet, phone and serial lines

Surge arresters for phone lines

Combination of coarse and fine surge protection for one pair of telecommunication lines. Suitable also for high-speed lines e.g. ISDN, ADSL or VDSL2.

DL-TLF-UHF



- Screw terminals
- Suitable also for ADSL and VDSL lines
- Universal plastic adapter for mounting on DIN rail in the scope of delivery
- LPZ 0 and higher

DL-ISDN RJ45



- RJ45 connectors
- Universal plastic adapter for mounting on DIN rail in the scope of delivery
- LPZ 1 and higher

Type	Location	U_c	I_L	I_n (C2) (8/20 μ s)	U_p (C3) core-core	U_p (C3) core-PE	f_{max}	Ordering number
DL-TLF-UHF	ST 2+3	162 V DC	0.06 A	2.5 kA	240 V	400 V	40 MHz	A07084
DL-ISDN RJ45	ST 2+3	121 V DC	0.06 A	2.5 kA	180 V	400 V	80 MHz	A03382

Surge arresters for high-speed xDSL lines

Two-stage protection for ADSL2, VDSL2 and VDSL3 high-speed lines (including the 35b profile). Installation at the entrance of the metallic cable into the building or close to the xDSL modem. LPZ 0 and higher.

DL-VDSL3



- Screw terminals
- Universal plastic adapter for mounting on DIN rail in the scope of delivery

Type	Location	Number of lines	U_c	I_L	I_n (C2) (8/20 μ s)	U_p (C3) core-core	U_p (C3) core-PE	Ordering number
DL-VDSL3	ST 1+2+3	60 V DC	0.6 A	5 kA	90 V (10 A)	600 V (10 A)	300 MHz	A07120

Surge arresters for Fast Ethernet Cat. 5e PoE

Combined coarse and fine protection of Ethernet line and the PoE part. Connection to the terminals and RJ45 connectors.

DL-Cat. 5e PoE plus



- Universal plastic adapter for mounting on DIN rail in the scope of delivery
- Terminals/RJ45 connector

Line part

- Wires 1, 2, 3, 6

Power part (PoE)

- $U_c = 76$ V DC
- $I_L = 1$ A
- Wires 4, 5, 7, 8

Type	Location	Number of lines	U_c	$I_{L(data)}$	I_n (C2) (8/20 μ s)	U_p (C3) core-core	U_p (C3) core-PE	Ordering number
DL-Cat.5e POE plus	ST 2+3	1	8.5 V DC	0.1 A	1.5 kA	60 V	560 V	A03806

SPDs for data / signalling / telecommunication networks

SPDs for Ethernet, telecommunication and serial lines

Fine protector for Ethernet networks with PoE and general structured cabling

Fine protector for Ethernet networks with PoE and general structured cabling. Installation close to protected equipment LPZ 1 and higher.

DL-Cat.6...



- DL-Cat.6. for lines without PoE
- DL-Cat.6A-60V for lines with PoE and general structured cabling
- RJ45 connectors
- Universal plastic adapter for mounting on DIN rail in the scope of delivery

Type	Location	Number of lines	U_c	I_L	I_n (C2) (8/20 μ s)	U_p (C3) core-core	U_p (C3) core-PE	Ordering number
DL-Cat.6A-60V	ST 2+3	1	60 V DC	0.5 A	0.2 kA	130 V	600 V	A07108
DL-Cat.6A	ST 2+3	1	8.5 V DC	0.5 A	0.2 kA	30 V	600 V	A06574

Surge arresters for Ethernet Cat. 6A with PoE and general structured cabling

Combination of coarse and fine protection of Ethernet lines Cat. 6 or 6A with possibility of PoE (Power over Ethernet) against surge voltage. LPZ 0 and higher.

DL-...-RJ45-PoE-AB



- PoE+/++ according to 802.3 af/at/bt standards
- Special surge protection of PoE pairs integrated
- RJ45 connectors
- Universal plastic adapter for mounting on DIN rail in the scope of delivery

DL-10G-PoE-IP66



- SPD for outdoor mounted Ethernet devices with PoE
- Desktop installation on tubular masts/pillars
- IP66 water and dust protection

DL-..G-60V-PoE



- For general structured cabling
- Suitable for all PoE types – PoE/PoE+/PoE++ (IEEE 802.3 af/at/bt)
- For structured cabling networks with signals with amplitudes up to 60 V (Ethernet, RS-485, KNX, DMX, ...)

Type	Location	Network type	U_c line/PoE	I_L line/PoE	I_n (C2) (8/20 μ s)	U_p (C3) core-core	U_p (C3) core-PE	Ordering number
DL-1G-RJ45-POE-AB	ST 1+2+3	1G	8.5/58 V DC	0.5 A	0.15 kA	45 V	500 V	A06148
DL-10G-RJ45-POE-AB	ST 1+2+3	10G	8.5/58 V DC	0.5 A	0.15 kA	45 V	500 V	A06149
DL-10G-PoE-IP66	ST 1+2+3	10G	8.5/58 V DC	0.5 A	0.15 kA	45 V	500 V	A07098
DL-1G-60V-PoE	ST 1+2+3	1G	60/60 V DC	0.5 A	0.15 kA	110 V	500 V	A07069
DL-10G-60V-PoE	ST 1+2+3	10G	60/60 V DC	0.5 A	0.15 kA	110 V	500 V	A07070

Surge arrester for RS interface

Fine protection for protection of serial ports of computers and control systems against effects of surge voltage.

DL-RS DD9



- DSUB 9 F/M connectors

Type	Location	U_c	I_n (C2) (8/20 μ s)	U_p (C3) core-core	U_p (C3) core-PE	f_{max}	Ordering number
DL-RS DD9	ST 3	18 V DC	0.15 kA	50 V	980 V	55 MHz	A00968

SPDs for data / signalling / telecommunication networks

SPDs for Ethernet, telecommunication and serial lines

Surge arrester for Power over Ethernet

RJ45 connectors

DL-1G-POE-INJECTOR



- Two-stage surge protection of Ethernet line in combination with protection of power supply over this line
- Installation at the entrance of a building, close to protected device, at the boundary of the LPZ 0 and LPZ 1 zones and higher ones
- To protect the Ethernet line Cat. 6 with PoE (power supply over Ethernet) in mode A or B against surge voltage

Type	Location	U _c line/PoE	I _L line/PoE	I _n (C2) (8/20 μs)	U _p (C3) core-core	U _p (C3) core-PE	Network speed	Ordering number
DL-1G-POE-INJECTOR	ST 1+2+3	8.5 / 58 V DC	0.5 / 1.5 A	10 kA	80 V	500 V	<1 Gbps	A06620

SPDs for Ethernet and other data lines for 19" RACK enclosures

Box for SPDs modules for 19" enclosure

DL-...-RACK-1U-...



- DL-PL-RACK-1U for DL- ...-M SPD and DL-...-R-M modules mounting
- DL-CS-RACK-1U-INJEKTOR for SPD modules DL-1G-POE-PCB-INJECTOR

Type	Ordering number
DL-PL-RACK-1U	A04163
DL-CS-RACK-1U-INJECTOR	A06569

Fine surge protection of Ethernet line and general structured cabling

DL-Cat.6A-M (-R-M)



- DL-Cat.6A-60V-M (-R-M): Fine SPD module for Ethernet with PoE and general structured cabling protection -M = with front output; -R-M = with rear output
- DL-Cat.6A-M (-R-M): Fine surge protection of Ethernet line WITHOUT PoE
- Installation close at protected device
- For protection of Ethernet networks up to Cat.6A
- For installation into DL-PL-RACK-1U box
- RJ45 connectors

Type	Location	Number of lines	U _c	I _L	I _n (C2)	U _p (C3) core-core	U _p (C3) core-PE	Ordering number
DL-Cat.6A-60V-M (-R-M)	ST 2+3	1	60 V DC	0.5 A	0.2 kA	130 V	600 V	A07110 (A07109)
DL-Cat.6A-M (-R-M)	ST 2+3	1	8.5 V DC	0.5 A	0.2 kA	30 V	600 V	A04196 (A04184)

SPDs for data / signalling / telecommunication networks

SPDs for Ethernet and other data lines for 19" RACK enclosures

Dual-stage SPD module for Ethernet with PoE

Two-stage Ethernet surge protection combined with power protection along this line

DL-...-POE-M



- Two-stage surge protection of Ethernet in combination with protection power supply along this line
- RJ45 connectors
- Installation at the entry of the line into building or close to the protected equipment, at the boundary of LPZ 0 and LPZ 1 or higher
- For protection of Ethernet line with PoE (Power over Ethernet) against surge voltage
- For installation into DL-PL-RACK-1U box
- suitable for all PoE types – PoE/PoE+/PoE++ (IEEE 802.3 af/at/bt)

Type	Location	Network speed	U _c line/PoE	I _L line/PoE	I _n (C2) (8/20 μs)	U _p (C3) core-core line/PoE	U _p (C3) core-PE	Ordering number
DL-1G-POE-M	ST 1+2+3	1G	8,5/58 V DC	0,5 A	0,15 kA	45/85 V	500 V	A04165
DL-10G-POE-M	ST 1+2+3	10G	8,5/58 V DC	0,5 A	0,15 kA	45/85 V	500 V	A04181

Dual-stage SPD module for Ethernet with PoE and general structured cabling

DL-...-60V-PoE-M



- RJ45 connectors
- Installation at the entry of the line into building or close to the protected equipment, at the boundary of LPZ 0 and LPZ 1 or higher
- To protect Ethernet with PoE and signals routed over structured UTP/FTP/STP cables Cat. 5e/Cat. 6 or Cat. 6A before pulse overvoltage
- For installation into DL-PL-RACK-1U box

Type	Location	Network speed	U _c	I _L	I _n (C2) (8/20 μs)	U _p (C3) core-core line/PoE	U _p (C3) core-PE	Ordering number
DL-1G-60V-PoE-M	ST 1+2+3	1G	60 V DC	0,5 A	0,15 kA	110 V	500 V	A07085
DL-10G-60V-PoE-M	ST 1+2+3	10G	60 V DC	0,5 A	0,15 kA	110 V	500 V	A07086

Surge arrester for Power over Ethernet

RJ45 connectors

DL-1G-POE-PCB-INJECTOR



- Two-stage Ethernet surge protection combined with PoE passive injector
- Installation at the entrance of a building, close to protected device, at the boundary of the LPZ 0 and LPZ 1 zones and higher ones
- To protect the Ethernet line, Cat.6, with PoE (Power over Ethernet) in mode A or B against the surge voltage
- For assembly into DL-CS-RACK-1U-INJECTOR

Type	Location	U _c line/PoE	I _L line/PoE	I _n (C2) (8/20 μs)	U _p (C3) core-core	U _p (C3) core-PE	Network speed	Ordering number
DL-1G-POE-PCB-INJECTOR	ST 1+2+3	8,5 / 58 V DC	0,5 / 1,5 A	0,15 kA	80 V	500 V	<1Gbps	A06570

SPDs for data / signalling / telecommunication networks

SPDs for video and coaxial lines

Surge arresters for video circuits

Combination of coarse and fine protection for video systems, CCTV, etc. against surge voltage. Installation close to protected equipment.

VL-B75 F/F



- BNC 75 Ω connectors or terminals
- Universal plastic adapter for mounting on DIN rail in the scope of delivery
- Floating line

Type	Location	U _c	I _L	I _n (C2) (8/20 μs)	U _p (C3) core-SH	U _p (C3) SH-PE	f _{max}	Ordering number
VL-B75 F/F	ST 2+3	6 V AC / 8.5 V DC	0.06 A	5 kA	35 V	350 V	150 MHz	A03376

Lightning current arresters for coaxial lines

Suitable for coaxial lines of telecommunication equipment against effects of direct or indirect lightning strike. Installation at the boundary of LPZ 0 and LPZ 1 zones at the line entry into building. Suitable for the combined signal and power supply installations (excl. ZX type). FX devices can be used as the 1st level of surge for protection in coordination with the SX type. For detailed RF parameters see www.saltek.eu

HX-... .50 F/...



- N or SMA 50 Ω connectors
- Suitable for the combined signal and power supply installations
- f = 0 – 3.8 GHz

FX-... ..75 ... F/F



- BNC or F 75 Ω connectors
- Universal plastic adapter for mounting on DIN rail in the scope of delivery
- f = 0 – 2.15 GHz
- Floating line



ZX-0,44 N50 F/...

- N 50 Ω connectors
- Narrowband
- f = 0.44 GHz
- Quarter-wave transformer
- B = 100 MHz

Type	Location	U _c	I _L	I _{imp} (D1) (10/350 μs)	I _n (C2) (8/20 μs)	U _{dyn} (1kA/μs)	f	Ordering number
HX-090 SMA F/M	ST 1+2	70 V DC	6 A	2.5 kA	10 kA	700 V	0–3.8 GHz	A04134
HX-090 N50 F/F	ST 1+2	70 V DC	6 A	2.5 kA	10 kA	700 V	0–3.8 GHz	A03405
HX-090 N50 F/M	ST 1+2	70 V DC	6 A	2.5 kA	10 kA	700 V	0–3.8 GHz	A03346
HX-230 N50 F/F	ST 1+2	180 V DC	6 A	2.5 kA	10 kA	800 V	0–3.8 GHz	A03511
HX-230 N50 F/M	ST 1+2	180 V DC	6 A	2.5 kA	10 kA	800 V	0–3.8 GHz	A03510
HX-350 N50 F/F	ST 1+2	250 V DC	6 A	2.5 kA	10 kA	900 V	0–3.5 GHz	A06703
HX-350 N50 F/M	ST 1+2	250 V DC	6 A	2.5 kA	10 kA	900 V	0–3.5 GHz	A06704
HX-470-N50 F/F	ST 1+2	360 V DC	6 A	2.5 kA	10 kA	980 V	0–3.0 GHz	A06556
HX-470-N50 F/M	ST 1+2	360 V DC	6 A	2.5 kA	10 kA	980 V	0–3.0 GHz	A06555
ZX-0,44 N50 F/F	ST 1+2+3	-	-	5 kA	20 kA	0.25 V	440 ± 50 MHz	A06207
ZX-0,44 N50 F/M	ST 1+2+3	-	-	5 kA	20 kA	0.25 V	440 ± 50 MHz	A06288
FX-090 B75 T F/F	ST 1	70 V	4 A	2.5 kA	10 kA	700 V	0–2.15 GHz	A03385
FX-090-F75 F/F	ST 1	70 V	4 A	2.5 kA	10 kA	700 V	0–2.30 GHz	A04212
FX-090 F75 T F/F	ST 1	70 V	4 A	2.5 kA	10 kA	700 V	0–2.15 GHz	A03387
FX-230 F75 T F/F	ST 1	180 V	4 A	2.5 kA	10 kA	800 V	0–2.15 GHz	A03392

Surge arrester for coaxial lines

Fine surge protection of coaxial inputs of TV and CCTV systems against surge voltage. Suitable as the 2nd level of surge protection in coordination with the FX type (! if floating line is not requested !). Installation close to protected equipment.

SX-090 ... F/F



- Shielding connected to ground
- BNC or F 75 Ω connectors
- Universal plastic adapter for mounting on DIN rail in the scope of delivery

Type	Location	U _c	I _L	I _n (C2) (8/20 μs)	U _p (C3) core-PE	f _{min}	f _{max}	Ordering number
SX-090-B50 F/F	ST 1+2+3	26 V DC	0.7 A	2.5 kA	85 V	DC	3 000 MHz	A04157
SX-090-F75 F/F	ST 1+2+3	26 V DC	0.7 A	2.5 kA	85 V	DC	2 300 MHz	A04158

SALTEK® SPD applications in data / signalling / telecommunication systems

MEASURING AND CONTROL TECHNOLOGY AND BUS SYSTEMS

Interface/Signal	Protected lines	U (DC) [V]	Discharge current per core		SPD xx – corresponding voltage	Mounting	Notes		
			10/350 µs	8/20 µs					
Current loop 0 ÷ 20 mA, 4 ÷ 20 mA	2	12/24	x	10 kA	DM-xx/1R DJ	DIN 35			
			x	5 kA	DM-xx/1-Ry*	DIN 35			
	2	12/24	x	5 kA	CLSA-xx	LSA plus	disconnection		
			2,5 kA	10 kA	BDM-xx-V/2-FR1	DIN 35			
	4		x	10 kA	2pcs DM-xx/1 R DJ	DIN 35			
	2	12/24	x	5 kA	DMG-xx/1-Ry*	DIN 35			
	2	12/24	2,5 kA	10 kA	BDG-xx-V/1-FR1	DIN 35			
Binary signals	2	6 ÷ 230	x	5 kA	CLSA-xx	LSA plus	disconnection		
			x	10 kA	DM-xx/1R DJ	DIN 35			
			2,5 kA	10 kA	BDM-xx-V/1-FR1	DIN 35			
			x	10 kA	DM-012/1R DJ	DIN 35			
BLN Building Level Network	2	15/48	2,5 kA	10 kA	BDM-xx-V/1-FR1	DIN 35			
			x	10 kA	DM-xx/1R DJ	DIN 35			
TTL	2	5	2,5 kA	10 kA	BDM-012-V/1-FR1	DIN 35			
			x	10 kA	DM-012/1R DJ	DIN 35			
RS-485 up to 1,5 Mbit/s	2	5	2,5 kA	10 kA	BDM-006-V/1-FR1	DIN 35			
			x	10 kA	DM-006/1R DJ	DIN 35			
	3	5	x	10 kA	DM-006/3R DJ	DIN 35			
	3/4	5	2,5 kA	10 kA	BDG-006-V/1-4FR1	DIN 35			
	4	5	x	10 kA	DM-006/4R DJ	DIN 35			
RS 485 combined with power line (e.g. security and fire alarm system)	2	12	x	10 kA	DMP-012-V/1-FR1	DIN 35			
		24	x	10 kA	DMP-024-V/1-FR1	DIN 35			
RS-422	2	5	2,5 kA	10 kA	BDM-006-V/1-FR1	DIN 35			
			x	10 kA	DM-006/1R DJ	DIN 35			
	4	5	2,5 kA	10 kA	BDG-006-V/1-4FR1	DIN 35			
			x	10 kA	DM-006/4R DJ	DIN 35			
Analog signals	I = 0,06 A	2	6 ÷ 48	x	10 kA	DM-xx/1-R DJ	DIN 35		
				x	10 kA	DM-xx/1-L DJ	DIN 35		
	I = 0,37 A	2	6 ÷ 48	x	5 kA	CLSA-xx	LSA plus	disconnection	
				6 ÷ 110	x	5 kA	DM-xx/1-Ry*	DIN 35	
				6 ÷ 110	x	5 kA	DMG-xx/1-Ry*	DIN 35	
				24	x	5 kA	DMLF-024/1-Ry*	DIN 35	
	I = 1 A	2	6 ÷ 230	2,5 kA	10 kA	BDM-xx-V/1-FR1	DIN 35		
				2,5 kA	10 kA	BDG-xx-V/1-FR1	DIN 35		
	I = 2 A	2	6 ÷ 48	x	10 kA	DM-xx/1- L2 DJ	DIN 35		
				2,5 kA	10 kA	BDM-xx-V/1-FR2	DIN 35		
				2,5 kA	10 kA	BDG-xx-V/1-FR2	DIN 35		
	Multipurpose coarse protection	2	70	2,5 kA	x	BD-090-T-V/2-F16	DIN 35		
RS-232-C	2	15	2,5 kA	10 kA	BDM-024-V/1-FR1	DIN 35	floating		
			x	10 kA	DM-024/1R DJ	DIN 35			
Measurement of temperature Pt-100, Pt-1000 Ni-1000, NTC, PTC	2	up to 6	x	5 kA	CLSA-006	LSA plus	disconnection		
			2,5 kA	10 kA	BDM-006-V/1-FR1	DIN 35			
			x	10 kA	DM-006/1R DJ	DIN 35			
	3	up to 6	x	10 kA	DM-006/3R DJ	DIN 35			
	3/4	up to 6	2,5 kA	10 kA	BDG-006-V/1-4FR1	DIN 35			
Optron protocol	2	6 ÷ 24	2,5 kA	10 kA	BDM-006-V/1-FR1	DIN 35	floating		
			x	10 kA	DM-xx/1R DJ	DIN 35			

* Ry means version of the terminal block: RS - screw terminals, RB - screwless terminals

SALTEK® SPD applications in data / signalling / telecommunication systems

MEASURING AND CONTROL TECHNOLOGY AND BUS SYSTEMS								
Interface/Signal	Protected lines	U (DC) [V]	Discharge current per core		SPD xx – corresponding voltage	Mounting	Notes	
			10/350 µs	8/20 µs				
DC power supply	I = 16 A	2	12 ÷ 48	x	2 kA	DP-xxxDC-16	DIN 35	
				x	2 kA	DP-xx-V/1-F16	DIN 35	
		2	12 ÷ 60	x	1 kA	DPF-xxxDC-16(-S)	DIN 35	RFi filter
KNX TP (EIB)	2	24	2,5 kA	10 kA	BDG-024-V/1-FR1	DIN 35		
			x	10 kA	DMG-024/1-RB	DIN 35		
M-Bus (Meter Bus)	2	36	2,5 kA	10 kA	BDM-048-V/1-FR1	DIN 35		
			2,5 kA	10 kA	DM-048/1R DJ	DIN 35		
CAN-Bus communication max. 1,5 Mbit/s	2	6	x	10 kA	DM-006/1R DJ	DIN 35		
			2,5 kA	10 kA	BDM-006-V/1-FR1	DIN 35		
Device Net communication 500 kbit/s	I = 2 A	2	24	2,5 kA	10 kA	BDM-024-V/1-FR2	DIN 35	
				x	10 kA	DM-024/1 L2 DJ	DIN 35	
	I = 2 A	2	5	2,5 kA	10 kA	BDM-006-V/1-FR2	DIN 35	
				x	10 kA	DM-006/1L2 DJ	DIN 35	
	I = 1 A	2	24	2,5 kA	10 kA	BDM-024-V/1-FR1	DIN 35	
				2,5 kA	10 kA	BDM-006-V/1-FR1	DIN 35	
C-Bus	2	5	x	10 kA	DM-006/1R DJ	DIN 35		
Honeywell communication max. 0,9 Mbit/s	2	5	2,5 kA	10 kA	BDM-006-V/1-FR1	DIN 35		
Dupline	2	15	2,5 kA	10 kA	BDG-012-V/1-FR1	DIN 35		
E-Bus (Honeywel)	2	48	2,5 kA	10 kA	BDG-048-V/1-FR1	DIN 35		
Fieldbus Foundation	2	30	2,5 kA	10 kA	BDG-048-V/1-FR1	DIN 35		
Genius I/O Bus	2	12	2,5 kA	10 kA	BDG-012-V/1-FR1	DIN 35		
FIPIO/FIPWAY	2	30	2,5 kA	10 kA	BDG-048-V/1-FR1	DIN 35		
INTERBUS INLINE	2	48	2,5 kA	10 kA	BDG-048-V/1-FR1	DIN 35		
K-Bus	2	24	2,5 kA	10 kA	BDG-024-V/1-FR1	DIN 35		
LUXMATE-Bus	2	24	2,5 kA	10 kA	BDG-024-V/1-FR1	DIN 35		
Procontic CS31 (RS-232)	2	15	2,5 kA	10 kA	BDM-024-V/1-FR1	DIN 35		
Profibus-DP/FMS high-speed lines	up to 1,5 Mbit/s	2	9	x	10 kA	DM-006/1R DJ	DIN 35	
		2	6	2,5 kA	10 kA	BDM-006-V/1-FR1	DIN 35	
	up to 20 Mbit/s	9	18	x	150 A	DL-RS DD9	Canon	
		2	6/15	x	5 kA	DMHF-xx/1-Ry*	DIN 35	
	up to 50 Mbit/s	3/4	6/24	2,5 kA	10 kA	BDMHF-xx-V/1-4FR1	DIN 35	
		2	6/24	2,5 kA	10 kA	BDMHF-xx-V/1-FR1	DIN 35	
		2	6 ÷ 24	2,5 kA	10 kA	BDGHF-xx-V/1-FR1	DIN 35	
2+2	6 ÷ 24	2,5 kA	10 kA	BDGHF-xx-V/2-FR1	DIN 35			
R-Bus	2	6	2,5 kA	10 kA	BDG-006-V/1-FR1	DIN 35		
SDLS	2	6	x	5 kA	CLSA-6	Krone LSA+		
Securilan-LON-Bus	2	6	2,5 kA	10 kA	BDG-006-V/1-FR1	DIN 35		
SIGMA SYS (Siemens EPS)	2	48	2,5 kA	10 kA	BDG-048-V/1-FR1	DIN 35		
SS97 SINIS (RS-232)	2	15	2,5 kA	10 kA	BDM-024-V/1-FR1	DIN 35		
SUCONET	2	6	2,5 kA	10 kA	BDG-006-V/1-FR1	DIN 35		
TELEPERM M analog input	2	12	2,5 kA	10 kA	BDM-012-V/1-FR1	DIN 35		
	2	24	2,5 kA	10 kA	BDM-024-V/1-FR1	DIN 35		
	2	12	x	5 kA	CLSA-12	Krone LSA+		
	2	24	x	5 kA	CLSA-24	Krone LSA+		
TELEPERM M binary I/O	2	48	x	10 kA	DM-048/1L DJ	DIN 35		
	2	48	2,5 kA	10 kA	BDM-048-V/1-FR1	DIN 35		
	2	12	x	10 kA	DM-012/1L DJ	DIN 35		
	2	12	2,5 kA	10 kA	BDM-012-V/1-FR1	DIN 35		
TELEPERM MFM100	2	12	2,5 kA	10 kA	BDG-012-V/1-FR1	DIN 35		
TTY	2	6 ÷ 24	x	10 kA	DM-xxx/1R DJ	DIN 35		
	2	6 ÷ 24	2,5 kA	10 kA	BDM-xxx-V/1-FR1	DIN 35		
Potential-free (isolated) contacts	1	6 ÷ 110	x	10 kA	DMJ-xx/2-Ry*	DIN 35		
			2,5 kA	10 kA	BDM-xx-V/2-JFR1	DIN 35		
			2,5 kA	10 kA	BDM-xx-V/2-JFR2	DIN 35		
			2,5 kA	10 kA	BDM-xx-V/4-JFR1	DIN 35		
			2,5 kA	10 kA	BDM-xx-V/4-JFR1	DIN 35		
Protection against power crossing of lines up to 400 V	2	24/48	x	5 kA	DMS-xx	DIN 35		

SALTEK® SPD applications in data / signalling / telecommunication systems

TELECOMMUNICATIONS, TELEPHONE SYSTEMS							
Interface/Signal	Protected lines	U (DC) (V)	Discharge current per core		SPD xx – corresponding voltage	Mounting	Notes
			10/350 µs	8/20 µs			
ADSL analog line	2	170	x	5 kA	CLSA-TLF	LSA plus	disconnection
			x	5 kA	CLSA-DSL	LSA plus	disconnection
			x	2,5 kA	DL-TLF-UHF	DIN 35	
			2,5 kA	10 kA	BDG-230-V/1-FR	DIN 35	
Analog telephone line	2	170	2,5 kA	x	BD-250-T-V/2-16	DIN 35	
			x	5 kA	CLSA-TLF	LSA plus	disconnection
			x	2,5 kA	DL-TLF-UHF	DIN 35	
			2,5 kA	10 kA	BDG-230-V/1-FR	DIN 35	
DATEX-P	2	24	2,5 kA	x	BD-250-T-V/2-16	DIN 35	
			x	5 kA	CLSA-24	LSA plus	disconnection
			x	5 kA	DMG-024/1-Ry*	DIN 35	
ISDN U _{ko}	2	120	2,5 kA	10 kA	BDG-024-V/1-FR1	DIN 35	
			x	2,5 kA	DL-ISDN RJ45	DIN 35	
Modem M1	2	15	x	5 kA	CLSA-ISDN	LSA plus	disconnection
			x	5 kA	CLSA-24	LSA plus	disconnection
			2,5 kA	10 kA	DMG-024 1R-Ry*	DIN 35	isolated signal ground
			2,5 kA	10 kA	BDG-024-V/1-FR1	DIN 35	
Telephony systems (eg. Siemens, HICOM, ALCATEL)	2	170	2,5 kA	10 kA	BDM-24-V/1-FR1	DIN 35	
			x	5 kA	CLSA-TLF	LSA plus	disconnection
			x	2,5 kA	DL-TLF-UHF	DIN 35	
T-DSL	2	170	2,5 kA	x	BD-250-T-V/2-16	DIN 35	
			x	5 kA	CLSA-DSL	LSA plus	disconnection
			x	5 kA	CLSA-TLF	LSA plus	disconnection
	2+2	170	x	2,5 kA	DL-TLF-UHF	DIN 35	
			2,5 kA	10 kA	BDGHF-230-V/1-FR	DIN 35	
			2,5 kA	10 kA	BDGHF-230-V/2-FR	DIN 35	
Multipurpose coarse protection	2	180	2,5 kA	x	BD-250-T-V/2-16	DIN 35	
			2,5 kA	x	BD-250-T-V/2-F16	DIN 35	
			2,5 kA	x	BD-090-T-V/2-16	DIN 35	
	70	180	2,5 kA	x	BD-090-T-V/2-F16	DIN 35	
			2,5 kA	x	BD-090-T	DIN 35	
			2,5 kA	x	BD-090-T	DIN 35	
VDSL	2	170	x	2,5 kA	FAX-OVERDRIVE ...		
			x	5 kA	CLSA-DSL	LSA plus	disconnection
			x	2,5 kA	DL-TLF-UHF	DIN 35	
			2,5 kA	x	BD-250-T-V/2-16	DIN 35	
VDSL2, VDSL3	2	60	x	2,5 kA	DL-VDSL3	DIN 35	

* Ry means version of the terminal: RS - screw, RB - screwless

SALTEK® SPD applications in data / signalling / telecommunication systems

ETHERNET AND GENERAL STRUCTURED CABLING								
Application	Protected pairs	Max. bitrate	Impulse current per core [A]		PoE compatibility (IEEE802.3)	SPD type	Mounting	LPZ location
			10/350 µs	8/20 µs				
Gigabit Ethernet (without PoE)	4	10 Gbps	x	200	NO	DL-Cat. 6A	DIN 35	LPZ 1 ->
	4	10 Gbps	x	200	NO	DL-Cat.6A-M (-R-M)	DL-PL-RACK-1U	LPZ 1 ->
Gigabit Ethernet with PoE	4	1 Gbps	250	150	af/at/bt	DL-1G-RJ45-PoE-AB	DIN 35	LPZ 0 _B ->
	4	10 Gbps	250	150	af/at/bt	DL-10G-RJ45-PoE-AB	DIN 35	LPZ 0 _B ->
	4	10 Gbps	250	150	af/at/bt	DL-10G-PoE-IP66	outdoor panel/pole	LPZ 0 ->
	4	1 Gbps	250	150	af/at/bt	DL-1G-POE-M	DL-PL-RACK-1U	LPZ 0 _B ->
	4	10 Gbps	250	150	af/at/bt	DL-10G-POE-M	DL-PL-RACK-1U	LPZ 0 _B ->
	4	10 Gbps	x	200	af/at/bt	DL-Cat.6A-60V-M (-R-M)	DL-PL-RACK-1U	LPZ 1 ->
	4	10 Gbps	x	200	af/at/bt	DL-Cat.6A-60V	DIN 35	LPZ 1 ->
Gigabit Ethernet PoE Injector	4	1 Gbps	250	150	af/at	DL-1G-POE-INJECTOR	DIN 35	LPZ 0 _B ->
	4	1 Gbps	250	150	af/at	DL-1G-POE-PCB-INJECTOR	DL-CS-RACK-1U-INJECTOR	LPZ 0 _B ->
General structured cabling (IP telephony, KNX, DMX, RS-485,...)	4	1 Gbps	250	150	af/at/bt	DL-1G-60V-PoE	DIN 35	LPZ 0 _B ->
	4	10 Gbps	250	150	af/at/bt	DL-10G-60V-PoE	DIN 35	LPZ 0 _B ->
	4	10 Gbps	x	200	af/at/bt	DL-Cat.6A-60V-M (-R-M)	DL-PL-RACK-1U	LPZ 1 ->
	4	1 Gbps	250	150	af/at/bt	DL-1G-60V-PoE-M	DL-PL-RACK-1U	LPZ 0 _B ->
	4	10 Gbps	250	150	af/at/bt	DL-10G-60V-PoE-M	DL-PL-RACK-1U	LPZ 0 _B ->
Ethernet, Fast Ethernet, Token Ring, CDDI/FDDI	4	10 Gbps	x	200	NO	DL-Cat. 6A	DIN 35	LPZ 1 ->
	2 + 1 PoE	500 Mbps	x	1500	af	DL-Cat.5e POE plus	DIN 35	LPZ 1 ->
	4	10 Gbps	x	200	NO	DL-Cat.6A-M (-R-M)	DL-PL-RACK-1U	LPZ 1 ->

SALTEK® SPD applications in data / signalling / telecommunication systems

TELECOMMUNICATIONS AND RADIOCOMMUNICATIONS (COAXIAL INTERFACES)									
Application	Power load CW* [W]	Frequency range [GHz]	Max. DC load [A]	Impulse current per core [kA]		SPD type	Connectors	Impedance	LPZ location
				10/350 µs	8/20 µs				
Transmitters	45	DC - 3,8	6	2,5	10	HX-090 SMA50	SMA (F/M)	50 Ω	LPZ 0 ->
	45	DC - 3,8	6	2,5	10	HX-090 N50	N (F/M,F/F)	50 Ω	LPZ 0 ->
	295	DC - 3,8	6	2,5	10	HX-230 N50	N (F/M,F/F)	50 Ω	LPZ 0 ->
	570	DC - 3,5	6	2,5	10	HX-350 N50	N (F/M,F/F)	50 Ω	LPZ 0 ->
	1175	DC - 3,0	6	2,5	10	HX-470 N50	N (F/M,F/F)	50 Ω	LPZ 0 ->
	tuning based	tuned (NB)	NO	5	20	ZX-xxx N50	N (F/F)	50 Ω	LPZ 0 ->
Transceivers, cellular networks (GSM, GSM-R, UMTS, 3G, LTE, 4G, 5G, TETRA,...)	45	DC - 3,8	6	2,5	10	HX-090 SMA50	SMA (F/M)	50 Ω	LPZ 0 ->
	45	DC - 3,8	6	2,5	10	HX-090 N50	N (F/M,F/F)	50 Ω	LPZ 0 ->
	295	DC - 3,8	6	2,5	10	HX-230 N50	N (F/M,F/F)	50 Ω	LPZ 0 ->
	570	DC - 3,5	6	2,5	10	HX-350 N50	N (F/M,F/F)	50 Ω	LPZ 0 ->
	1175	DC - 3,0	6	2,5	10	HX-470 N50	N (F/M,F/F)	50 Ω	LPZ 0 ->
	tuning based	tuned (NB)	NO	5	20	ZX-xxx N50	N (F/F)	50 Ω	LPZ 0 ->
Professional receivers (GPS, Galileo, Glonass, Beidou, SAT LNB, measuring and monitoring receivers,...)	x	DC - 3,8	6	2,5	10	HX-090 SMA50	SMA (F/M)	50 Ω	LPZ 0 ->
	x	DC - 3,8	6	2,5	10	HX-090 N50	N (F/M,F/F)	50 Ω	LPZ 0 ->
	x	DC - 3,0	0,7	0,5	2,5	SX-090-B50 F/F	BNC (F/F)	50 Ω	LPZ 0 _B ->
	x	DC - 2,15	4	2,5	10	FX-090-F75 F/F	F (F/F)	75 Ω	LPZ 0 ->
	x	DC - 2,15	0,7	0,5	2,5	SX-090-F75 F/F	F (F/F)	75 Ω	LPZ 0 _B ->
Commercial TV/SAT receivers (DVB-T2, DVB-S2,...)	x	DC - 2,15	4	2,5	10	FX-090-F75 T F/F	F (F/F)	75 Ω	LPZ 0 ->
	x	DC - 2,15	0,7	0,5	2,5	SX-090-F75 F/F	F (F/F)	75 Ω	LPZ 0 _B ->
Microwave PtP links (split)	45	DC - 3,8	6	2,5	10	HX-090 SMA50	SMA (F/M)	50 Ω	LPZ 0 ->
	45	DC - 3,8	6	2,5	10	HX-090 N50	N (F/M,F/F)	50 Ω	LPZ 0 ->
Microwave PtP links (all outdoor)	x	0,5	2x 1 (PoE)	0,25	0,15	DL-10G-PoE-IP66	RJ45	100 Ω	LPZ 0 ->
Coaxial video networks (CCTV, analogue)	x	0,15	0,06	x	5	VL-B75 F/F	BNC (F/F)	75 Ω	LPZ 1 ->
	x	DC - 2,15	4	2,5	10	FX-090-F75 F/F	F (F/F)	75 Ω	LPZ 0 ->
	x	DC - 2,15	0,7	0,5	2,5	SX-090-F75 F/F	F (F/F)	75 Ω	LPZ 0 _B ->
WLAN, WiFi (coaxial interfaces)	45	DC - 3,8	6	2,5	10	HX-090 SMA50	SMA (F/M)	50 Ω	LPZ 0 ->
	45	DC - 3,8	6	2,5	10	HX-090 N50	N (F/M,F/F)	50 Ω	LPZ 0 ->
	x	DC - 3,0	0,7	0,5	2,5	SX-090-B50 F/F	BNC (F/F)	50 Ω	LPZ 0 _B ->

* A correction related to the signal peak power (PAPR, Crest factor) should be done for digital signal modulations (OFDM etc.)

Notes

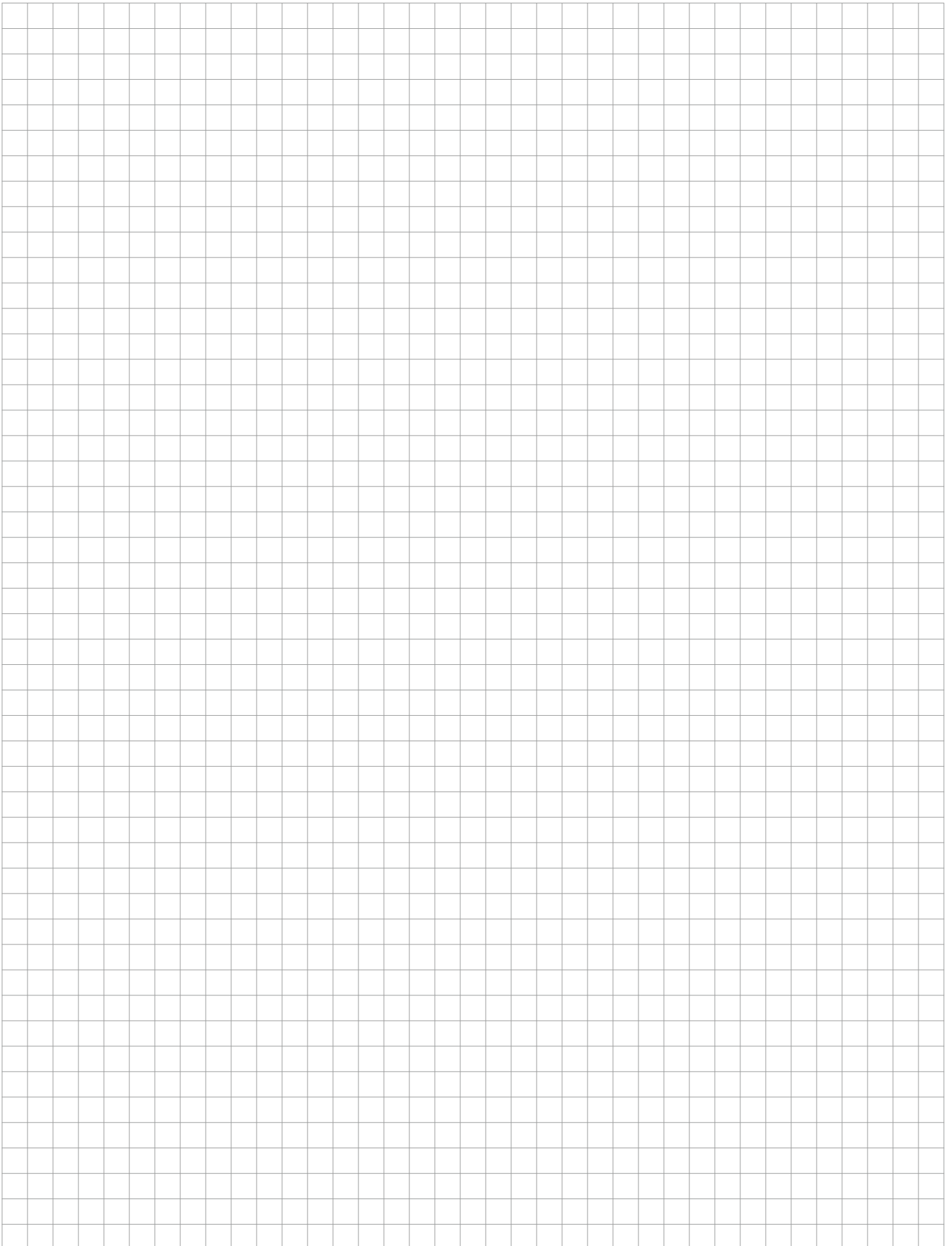

SALTEK s.r.o.
Drážďanská 85
400 07 Ústí nad Labem
Czech Republic
Phone: +420 272 942 470
E-mail: info@saltek.cz
www.saltek.eu/en

Distributor:

--